



OPTIBAR P 2010 C Handbook

Hygienic pressure transmitter with flush welded diaphragm

All rights reserved. It is prohibited to reproduce this documentation, or any part thereof, without the prior written authorisation of KROHNE Messtechnik GmbH.

Subject to change without notice.

Copyright 2014 by
KROHNE Messtechnik GmbH - Ludwig-Krohne-Str. 5 - 47058 Duisburg (Germany)

1	Safety instructions	5
1.1	Intended use	5
1.2	Technical limits	5
1.3	Certification	5
1.4	Safety instructions from the manufacturer	6
1.4.1	Copyright and data protection	6
1.4.2	Disclaimer	6
1.4.3	Product liability and warranty	7
1.4.4	Information concerning the documentation	7
1.4.5	Warnings and symbols used	8
1.5	Safety instructions for the operator	8
2	Device description	9
2.1	Scope of delivery	9
2.2	Nameplate	10
3	Installation	11
3.1	General notes on installation	11
3.2	Installation specifications	11
3.3	Mounting	12
3.3.1	Installation steps for connections acc. to DIN 3852	12
3.3.2	Installation steps for connections acc. to EN 837	13
3.3.3	Installation steps for NPT connections	13
3.3.4	Installation steps for dairy pipe connections	14
3.3.5	Installation steps for clamp and Varivent connections	14
3.3.6	Installation steps for flange connections	14
4	Electrical connections	15
4.1	Safety instructions	15
4.2	Terminal assignment	15
4.3	Electrical connection diagram	16
5	Service	17
5.1	Maintenance	17
5.2	Recalibration	17
5.3	Spare parts availability	18
5.4	Availability of services	18
5.5	Repairs	18
5.6	Returning the device to the manufacturer	18
5.6.1	General information	18
5.6.2	Form (for copying) to accompany a returned device	19
5.7	Disposal	19

6 Technical data	20
6.1 Technical data.....	20
6.2 Dimensions and weights	23
6.3 Measuring ranges.....	26
7 Notes	27

1.1 Intended use

**CAUTION!**

Responsibility for the use of the measuring devices with regard to suitability, intended use and corrosion resistance of the used materials against the measured fluid lies solely with the operator.

**INFORMATION!**

The manufacturer is not liable for any damage resulting from improper use or use for other than the intended purpose.

The **OPTIBAR P 2010 C** pressure transmitter is designed to measure the absolute pressure and gauge pressure of gases and liquids.

1.2 Technical limits

The device was constructed solely for use within the technical limits indicated on the nameplate and in the technical data. Applications outside of these limits are not permitted and could lead to significant risk of accident. For this reason, observe the following limits:

- Do not exceed the maximum working pressure (MWP).
- Do not exceed the indicated permissible operating temperature range.
- The permissible ambient temperatures given may not be exceeded or undershot.
- Observe the ingress protection of the housing during use.

1.3 Certification

CE marking

The device fulfils the statutory requirements of the following EC directives:

- EMC Directive 2004/108/EC
- EMC specification acc. to EN 61326/A1

The manufacturer certifies successful testing of the product by applying the CE marking.

Pressure equipment directive (PED)

Devices with a permissible pressure $PS \leq 200$ bar (20 MPa) comply with Article 3 Section (3) and are not subject to a conformity assessment. These devices were designed and manufactured in accordance with sound engineering practice (SEP).

The CE marking on the device does not apply to the Pressure Equipment Directive.

**DANGER!**

For devices used in hazardous areas, additional safety notes apply; please refer to the Ex documentation.

1.4 Safety instructions from the manufacturer

1.4.1 Copyright and data protection

The contents of this document have been created with great care. Nevertheless, we provide no guarantee that the contents are correct, complete or up-to-date.

The contents and works in this document are subject to copyright. Contributions from third parties are identified as such. Reproduction, processing, dissemination and any type of use beyond what is permitted under copyright requires written authorisation from the respective author and/or the manufacturer.

The manufacturer tries always to observe the copyrights of others, and to draw on works created in-house or works in the public domain.

The collection of personal data (such as names, street addresses or e-mail addresses) in the manufacturer's documents is always on a voluntary basis whenever possible. Whenever feasible, it is always possible to make use of the offerings and services without providing any personal data.

We draw your attention to the fact that data transmission over the Internet (e.g. when communicating by e-mail) may involve gaps in security. It is not possible to protect such data completely against access by third parties.

We hereby expressly prohibit the use of the contact data published as part of our duty to publish an imprint for the purpose of sending us any advertising or informational materials that we have not expressly requested.

1.4.2 Disclaimer

The manufacturer will not be liable for any damage of any kind by using its product, including, but not limited to direct, indirect or incidental and consequential damages.

This disclaimer does not apply in case the manufacturer has acted on purpose or with gross negligence. In the event any applicable law does not allow such limitations on implied warranties or the exclusion of limitation of certain damages, you may, if such law applies to you, not be subject to some or all of the above disclaimer, exclusions or limitations.

Any product purchased from the manufacturer is warranted in accordance with the relevant product documentation and our Terms and Conditions of Sale.

The manufacturer reserves the right to alter the content of its documents, including this disclaimer in any way, at any time, for any reason, without prior notification, and will not be liable in any way for possible consequences of such changes.

1.4.3 Product liability and warranty

The operator shall bear responsibility for the suitability of the device for the specific purpose. The manufacturer accepts no liability for the consequences of misuse by the operator. Improper installation and operation of the devices (systems) will cause the warranty to be void. The respective "Standard Terms and Conditions" which form the basis for the sales contract shall also apply.

1.4.4 Information concerning the documentation

To prevent any injury to the user or damage to the device it is essential that you read the information in this document and observe applicable national standards, safety requirements and accident prevention regulations.

If this document is not in your native language and if you have any problems understanding the text, we advise you to contact your local office for assistance. The manufacturer can not accept responsibility for any damage or injury caused by misunderstanding of the information in this document.

This document is provided to help you establish operating conditions, which will permit safe and efficient use of this device. Special considerations and precautions are also described in the document, which appear in the form of underneath icons.

1.4.5 Warnings and symbols used

Safety warnings are indicated by the following symbols.



DANGER!

This warning refers to the immediate danger when working with electricity.



DANGER!

This warning refers to the immediate danger of burns caused by heat or hot surfaces.



DANGER!

This warning refers to the immediate danger when using this device in a hazardous atmosphere.



DANGER!

These warnings must be observed without fail. Even partial disregard of this warning can lead to serious health problems and even death. There is also the risk of seriously damaging the device or parts of the operator's plant.



WARNING!

Disregarding this safety warning, even if only in part, poses the risk of serious health problems. There is also the risk of damaging the device or parts of the operator's plant.



CAUTION!

Disregarding these instructions can result in damage to the device or to parts of the operator's plant.



INFORMATION!

These instructions contain important information for the handling of the device.



LEGAL NOTICE!

This note contains information on statutory directives and standards.



• **HANDLING**

This symbol designates all instructions for actions to be carried out by the operator in the specified sequence.

➔ **RESULT**

This symbol refers to all important consequences of the previous actions.

1.5 Safety instructions for the operator



WARNING!

In general, devices from the manufacturer may only be installed, commissioned, operated and maintained by properly trained and authorized personnel.

This document is provided to help you establish operating conditions, which will permit safe and efficient use of this device.

2.1 Scope of delivery

**INFORMATION!**

Inspect the packaging carefully for damages or signs of rough handling. Report damage to the carrier and to the local office of the manufacturer.

**INFORMATION!**

Do a check of the packing list to make sure that you have all the elements given in the order.

**INFORMATION!**

Look at the device nameplate to ensure that the device is delivered according to your order. Check for the correct supply voltage printed on the nameplate.

The following items are supplied with the device:

- Measuring device in ordered version
- For mechanical connections DIN 3852: O-ring (pre-assembled)
- Product documentation

**INFORMATION!**

Assembly materials and tools are not part of the delivery. Use the assembly materials and tools in compliance with the applicable occupational health and safety directives.

2.2 Nameplate



INFORMATION!

Look at the device nameplate to ensure that the device is delivered according to your order. Check for the correct supply voltage printed on the nameplate.

The device can be identified by its nameplate. It provides the most important data.

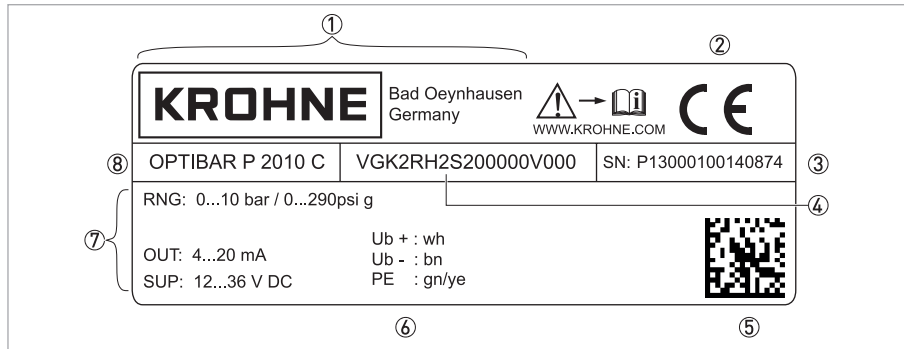

Figure 2-1: Example for nameplate

- ① Manufacturer logo and address
- ② CE marking and other approvals (e.g. ATEX, PED,...)
- ③ Serial number
- ④ Type code
- ⑤ Barcode
- ⑥ Electrical connection diagram
- ⑦ Specifications for process conditions (measuring range, MWP [= Maximum Working Pressure] and electrical data (signal output and power supply))
- ⑧ Product name

3.1 General notes on installation

**INFORMATION!**

Inspect the packaging carefully for damages or signs of rough handling. Report damage to the carrier and to the local office of the manufacturer.

**INFORMATION!**

Do a check of the packing list to make sure that you have all the elements given in the order.

**INFORMATION!**

Look at the device nameplate to ensure that the device is delivered according to your order. Check for the correct supply voltage printed on the nameplate.

3.2 Installation specifications

**WARNING!**

Install the device only when depressurised and without power!

**DANGER!**

For installation the respective regulations for explosion protection have to be fulfilled.

**INFORMATION!**

For installations outdoor and in damp areas, the following points must be observed:

- *To ensure that no moisture can get into the connector, the device should be connected electrically immediately after installation. Otherwise a moisture admission has to be prevented e.g. by using a suitable protection cap.*
- *Select an installation if possible, where a mounting position allows draining of spray and condensate. Sealing surfaces should not be submerged!*
- *When using devices with cable glands or output, the cable should be looped facing down so that any liquid that collects on the cable can drip off.*
- *Install the device so it is protected from direct sunlight. In the worst case scenario, the permissible operating temperature will be exceeded in the presence of direct sunlight. This can negatively affect or damage the functionality of the device. In addition, it can lead to temporary measuring errors if the internal pressure of the device increases due to the sunlight.*
- *When installing outside where the risk of lightning or overvoltage may exist and damage the device, we recommend installing suitable overvoltage protection between the supply device or control cabinet and the device.*

**INFORMATION!**

- Handle this highly sensitive electronic measuring device with care, both in and out of the packaging!
- Only remove the packaging and any protection cap from the device immediately before installing to prevent damage to the diaphragm! Keep the supplied protection cap! Remove the protection cap slowly and carefully to avoid any negative pressure on the diaphragm.
- Handle the unprotected diaphragm with extreme care; it is very easily damaged.
- A device with a gauge reference in the housing (small hole next to the electrical connection) must be installed so that the gauge reference necessary for measurement is protected from dirt and moisture. Should the pressure transmitter be exposed to fluid admission, the air pressure compensation is blocked by the gauge reference. Accurate measurement in this state is not possible. It can also result in damage to the pressure transmitter.
- Ensure that no mechanical stress is applied to the pressure port during installation as this may result in a shift in the characteristic curve. This applies in particular to very small pressure ranges as well as to devices with plastic pressure ports.
- With hydraulic systems, arrange the device so that the pressure port faces up (venting).
- Provide cooling fins when using on steam lines.

3.3 Mounting

**CAUTION!**

- Prior to installing the pressure transmitter, it is essential to verify whether the version of the device on hand completely fulfils the technical and safety requirements of the measuring point. This applies in particular to the measuring range, overpressure resistance, temperature, explosion protection and operating voltage.
- Check the materials used for the wetted parts (e.g. gasket, process connection, separating diaphragm etc.) for suitability as regards process compatibility.

3.3.1 Installation steps for connections acc. to DIN 3852



- Ensure that the O-ring is positioned in the slot provided.
- Ensure that the raised face of the receiving part has a smooth surface.
- Screw the device into the thread by hand.
- Devices with wrench flats must be tightened with a wrench. For information on tightening torque see the following table.

Wrench size	Tightening torque [Nm]
Wrench size of steel	
G¼"	approx. 5
G½"	approx. 10
G¾"	approx. 15
G1"	approx. 20
G1½"	approx. 25
Wrench size of plastic	
All sizes	max. 3

3.3.2 Installation steps for connections acc. to EN 837



- When sealing, use a suitable gasket that corresponds to the product and pressure to be measured (e.g. a copper gasket).
- Ensure that the raised face of the receiving part has a smooth surface.
- Screw the device into the thread by hand.
- Then tighten the device with the wrench.

Wrench size	Tightening torque [Nm]
G $\frac{1}{4}$ "	approx. 20
G $\frac{1}{2}$ "	approx. 50

3.3.3 Installation steps for NPT connections



- When sealing, use a suitable sealing agent that is compatible with the product (e.g. PTFE tape).
- Screw the device into the thread by hand.
- Then tighten the device with the wrench.

Wrench size	Tightening torque [Nm]
$\frac{1}{4}$ NPT	approx. 30
$\frac{1}{2}$ NPT	approx. 70

3.3.4 Installation steps for dairy pipe connections



- Ensure that the O-ring is positioned in the slot provided in the fitting.
- Centre the dairy connection in the corresponding fitting.
- Screw the union nut onto the fitting.
- Then tighten it with a hook wrench.

3.3.5 Installation steps for clamp and Varivent connections

Notes for versions acc. to 3A standard



INFORMATION!

The device must be assembled according to 3A standard 74-06.

The device has to be installed in the way that drainability (E1.8.1) and demands acc. to L1.1 are met. The device must be installed with the pressure port downwards or to the side.

The user is responsible for:

- using a suitable sealing material
- defining adequate service intervals
- using an elastomer sealing material according to 3A standard 18-03 and 21CFR177.2600
- the right dimension of the gasket

Make sure that welding sockets are mounted flush inside the tank.

General procedure



- When sealing, use a suitable gasket that corresponds to the product and pressure to be measured.
- Place the gasket on the corresponding fitting.
- Centre the clamp or Varivent connection over the corresponding fitting and gasket.
- Then use a suitable connecting element (e.g. half ring or clamp ring connection) to attach the device according to the manufacturer's specifications.

3.3.6 Installation steps for flange connections



- When sealing, use a suitable gasket that corresponds to the product and pressure to be measured (e.g. a fibre gasket)
- Put the gasket between connecting flange and counter flange.
- Then fasten the device using 4 or 8 screws (depending on flange version) to the counter flange.

4.1 Safety instructions



DANGER!

All work on the electrical connections may only be carried out with the power disconnected. Take note of the voltage data on the nameplate!



DANGER!

Observe the national regulations for electrical installations!



DANGER!

For devices used in hazardous areas, additional safety notes apply; please refer to the Ex documentation.



WARNING!

Observe without fail the local occupational health and safety regulations. Any work done on the electrical components of the measuring device may only be carried out by properly trained specialists.



INFORMATION!

Look at the device nameplate to ensure that the device is delivered according to your order. Check for the correct supply voltage printed on the nameplate.

4.2 Terminal assignment



WARNING!

Install the device only when depressurised and without power!

Electrical connections	ISO 4400	M12x1 (4-pin)	Field housing	Cable colours (DIN 47100)
-			-	-
Supply +	1	1	IN +	wh (white)
Supply -	2	2	IN -	bn (brown)
Shielding	Ground contact	4	-	gn/ye (green/yellow)

Devices with cable glands and cable connector

Ensure that the outer diameter of the cable used is within the permissible clamping range. Also ensure that it is sitting firmly in the cable gland with no gaps!

Devices with cable output

Observe the following minimum bending radii when laying the cable:

- Cable without venting:
static installation: 5-times the cable diameter
dynamic application: 10-times the cable diameter
- Cable with venting:
static installation: 10-times the cable diameter
dynamic application: 20-times the cable diameter

Devices with cable output and integrated venting

The PTFE filter at the end of the cable on the venting port may not be damaged or removed. For the electrical connection it is preferable to use a shielded and twisted multicore cable.

Devices with ISO 4400 connector

Ensure that the cable connector is properly installed to guarantee the protection category indicated! Ensure that the gasket supplied is installed between the plug and the cable connector. After connecting the cable, fasten the cable connector to the device using the screw.

Devices with field housing

With these devices, the connection terminals are under the housing cover. To electrically connect the device, the cover must first be unscrewed. Before screwing the cover back on, check the O-ring and raised face on the housing for damage and replace if necessary! Screw the cover back on by hand and ensure that the field housing is firmly closed.

4.3 Electrical connection diagram

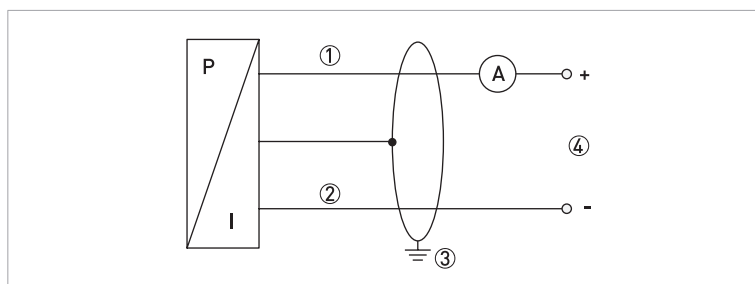

Figure 4-1: Electrical connection diagram

- ① Supply +
- ② Supply -
- ③ Shielding
- ④ Supply voltage V_S

5.1 Maintenance

In principal, the device is maintenance free. If necessary, clean the device housing when switched off using a damp cloth and a non-aggressive cleaning solution.

Depending on the product, deposits or contamination can still occur on the diaphragm. If the product has a known affinity, the operator must determine the cleaning intervals accordingly. Once the device has been properly taken out of commission, the diaphragm can generally be carefully cleaned using a non-aggressive cleaning solution and a soft brush or sponge. If the diaphragm is calcified, decalcification by the manufacturer is recommended.



INFORMATION!

Improper cleaning can result in irreparable damage to the measuring cell. For this reason, never use sharp objects or compressed air to clean the diaphragm.

5.2 Recalibration

During the life cycle of the device, the offset or full-scale of the device may shift. If this occurs, note that the signal value output will deviate based on the set start or end value of the measuring range. If one of these phenomena does occur following prolonged use, recalibration is recommended to ensure continued high accuracy.

5.3 Spare parts availability

The manufacturer adheres to the basic principle that functionally adequate spare parts for each device or each important accessory part will be kept available for a period of 3 years after delivery of the last production run for the device.

This regulation only applies to spare parts which are subject to wear and tear under normal operating conditions.

5.4 Availability of services

The manufacturer offers a range of services to support the customer after expiration of the warranty. These include repair, maintenance, technical support and training.



INFORMATION!

For more precise information, please contact your local sales office.

5.5 Repairs

Repairs may be carried out exclusively by the manufacturer or the manufacturer authorised specialist companies.

5.6 Returning the device to the manufacturer

5.6.1 General information

This device has been carefully manufactured and tested. If installed and operated in accordance with these operating instructions, it will rarely present any problems.



CAUTION!

Should you nevertheless need to return a device for inspection or repair, please pay strict attention to the following points:

- *Due to statutory regulations on environmental protection and safeguarding the health and safety of our personnel, manufacturer may only handle, test and repair returned devices that have been in contact with products without risk to personnel and environment.*
- *This means that the manufacturer can only service this device if it is accompanied by the following certificate (see next section) confirming that the device is safe to handle.*



CAUTION!

If the device has been operated with toxic, caustic, flammable or water-endangering products, you are kindly requested:

- *to check and ensure, if necessary by rinsing or neutralising, that all cavities are free from such dangerous substances,*
- *to enclose a certificate with the device confirming that is safe to handle and stating the product used.*

5.6.2 Form (for copying) to accompany a returned device

Company:		Address:	
Department:		Name:	
Tel. no.:		Fax no.:	
Manufacturer's order no. or serial no.:			
The device has been operated with the following medium:			
This medium is:	water-hazardous		
	toxic		
	caustic		
	flammable		
	We checked that all cavities in the device are free from such substances.		
	We have flushed out and neutralized all cavities in the device.		
We hereby confirm that there is no risk to persons or the environment through any residual media contained in the device when it is returned.			
Date:		Signature:	
Stamp:			

5.7 Disposal



CAUTION!

Disposal must be carried out in accordance with legislation applicable in your country.

6.1 Technical data



INFORMATION!

- The following data is provided for general applications. If you require data that is more relevant to your specific application, please contact us or your local sales office.
- Additional information (certificates, special tools, software,...) and complete product documentation can be downloaded free of charge from the website (Download Center).

Measuring system

Measuring principle	Piezoresistive measuring cell
Application range	Measurement of gauge and absolute pressure in gases and liquids
Measuring range	-1...40 bar / -14.5...580 psi; refer also to chapter "Measuring ranges"

Measuring accuracy

Reference conditions	Medium: air
	Temperature: ambient temperature
	Ambient pressure: 1013 mbar / 14.7 psi
	Nominal position: vertical, pressure port down
	Power supply: 24 VDC
Pressure type	Gauge pressure / absolute pressure
Measuring accuracy according to IEC 60770 (terminal based) (Hysteresis, non-linearity, non-repeatability)	Nominal pressure (P_N) < 0.4 bar / 5.8 psi: $\leq \pm 0.5\%$ of URL
	Nominal pressure (P_N) > 0.4 bar / 5.8 psi: $\leq \pm 0.25\%$ of URL (URL = Upper Range Limit)
Ambient temperature effect on zero and span	Nominal pressure (P_N) < 0.4 bar / 5.8 psi: $\leq \pm 1.5\%$ of URL in compensated range of 0...+50°C / +32...+122°F
	Nominal pressure (P_N) > 0.4 bar / 5.8 psi: $\leq \pm 0.75\%$ of URL in compensated range of -10...+85°C / +14...+185°F
	Nominal pressure (P_N) = -1...0 bar / -14.5...0 psi: $\leq \pm 0.75\%$ of URL
Long-term stability	$\leq \pm 0.1\%$ of URL within one year under reference conditions
Step response time	< 10 ms (T90)
Vacuum resistance	$P_N \geq 1$ bar / 14.5 psi: vacuum resistant
	$P_N < 1$ bar / 14.5 psi: on request

Operating conditions

Temperature	
Nominal temperature	-20...+80°C / -4...+176°F
Ambient temperature	-40...+85°C / -40...+185°F
	Ex i zone 0: -20...+60°C / -4...+140°F at $p_{abs} = 0.8...1.1$ bar
	Ex i from zone 1: -20...+70°C / -4...+158°F
Storage temperature	-40...+100°C / -40...+212°F
Medium temperature	Silicone oil: -40...+125°C / -40...+257°F
	Food grade oil: -10...+125°C / +14...+257°F
	With cooling fins (optional):
	Silicone oil: $P_N > 0$ barg: -40...+300°C / -40...+572°F; $P_N < 0$ barg: -40...+150°C / -40...+302°F Food grade oil: $P_N > 0$ barg: -10...+250°C / +14...+482°F; $P_N < 0$ barg: -10...+150°C / +14...+301°F
CIP/SIP	Max. medium temperature for gauge pressure range $p > 0$ bar is +150°C / +302°F for 60 minutes at max. ambient temperature of +50°C / +122°F
Other conditions	
Ingress protection acc. to IEC 529 / EN 60529	Connector M16 ISO 4400: IP65
	Connector M12x1, 4-pin: IP67
	Cable PUR: IP67
	Cable PUR with venting: IP68 (1mWS / 24h)
	Thread M12, housing in 1.4404 / AISI 316L: IP67

Installation conditions

Mounting position	Any - factory calibration carried out with pressure port down.
Dimensions	For detailed information refer to chapter "Dimensions and weights".
Weight	Min. 200 g / 0.44 lb (depending on pressure port)

Materials

Housing	Stainless steel 1.4404 / AISI 316L
	Field housing (optional): stainless steel 1.4301 / AISI 304
Cable gland	Nickel-plated brass
Fill fluid	Silicone oil
	Food grade oil with FDA approval (Mobil DTE FM 32; Category Code: H1; NSF Registration No.: 130662)
Wetted parts	
Pressure port	Stainless steel 1.4404 / AISI 316L
Separating diaphragm	Stainless steel 1.4435 / AISI 316L; 2.4819 / Hastelloy® C-276
Gasket	Optional and only for DIN threads
	FKM (medium temperature $\leq +200^\circ\text{C}$ / $+392^\circ\text{F}$); FFKM (medium temperature $> +200^\circ\text{C}$ / $+392^\circ\text{F}$)

Surface roughness	
Turning parts	$R_a \leq 0.8 \mu\text{m}$
Diaphragm	$R_a \leq 0.4 \mu\text{m}$
Weld seams	Approx. $R_a \leq 1.5 \mu\text{m}$

Process connections

Thread	Thread ISO 228 G $\frac{1}{2}$ ", DIN 3852 ($P_N \geq 1 \text{ bar} / 14.5 \text{ psi}$)
	Thread ISO 228 G $\frac{3}{4}$ ", DIN 3852 ($P_N \geq 600 \text{ mbar} / 8.7 \text{ psi}$); thread ISO 228 G1", DIN 3852; Thread ISO 228 G1", cone
Clamp	Clamp DN25 ISO 2852; clamp DN38 ISO 2852; clamp DN51 ISO 2852; dairy pipe DN25 DIN 11851; dairy pipe DN40 DIN 11851; dairy pipe DN50 DIN 11851 Others on request.

Electrical connection

Output signal	4...20 mA current output; 2-wire
Power supply	Standard: $U_b = 8...32 \text{ VDC}$
	Ex i: $U_b = 10...28 \text{ VDC}$
Safety maximum values (Ex i)	$U_i = 28 \text{ V}$, $I_i = 93 \text{ mA}$, $P_i = 660 \text{ mW}$, $C_i \approx 0 \text{ nF}$, $L_i \approx 0 \mu\text{H}$; The supply connections have a maximum internal capacity of 27 nF to the housing.
Load	$R_{l\text{max}} \leq (U_b - U_{b\text{min}}) / 0.02 \text{ A [Ohm]}$
Short circuit protection	Continuously
Reverse polarity protection	In the event of reversed connections there is no damage but also no function.
Ripple	0.05% of URL / 10 V
Electrical connection	Connector M16 ISO 4400
	Connector M12x1, 4-pin
	Cable PUR
	Cable PUR with venting
	Thread M12, housing 316L

Approvals and certificates

CE	The device fulfils the statutory requirements of the EC directives. The manufacturer certifies that these requirements have been met by applying the CE marking.
Electromagnetic compatibility (EMC) acc. to EN 61326	EMC Directive: 2004/108/EC
	For more information consult the relevant declaration of conformity.
Pressure equipment directive	97/23/EC
Ex	
ATEX	II 1G Ex ia IIC T4 or II 1D Ex ia T85°C
IECEX	Ex ia IIC T4 Ga ot Ex ia IIIC T85°C Da

Other standards and approvals	
Vibration resistance acc. to EN 60068-2-6	G½": 20g RMS (25...2000 Hz)
	All except G½": 10g RMS (25...2000 Hz)
Shock resistant (impact) according to EN 60068-2-27	G½": 500g / 1 ms
	All except G½": 100g / 1 ms
Hygiene	3-A approved; FDA approved materials

6.2 Dimensions and weights

Connection plug and field housing

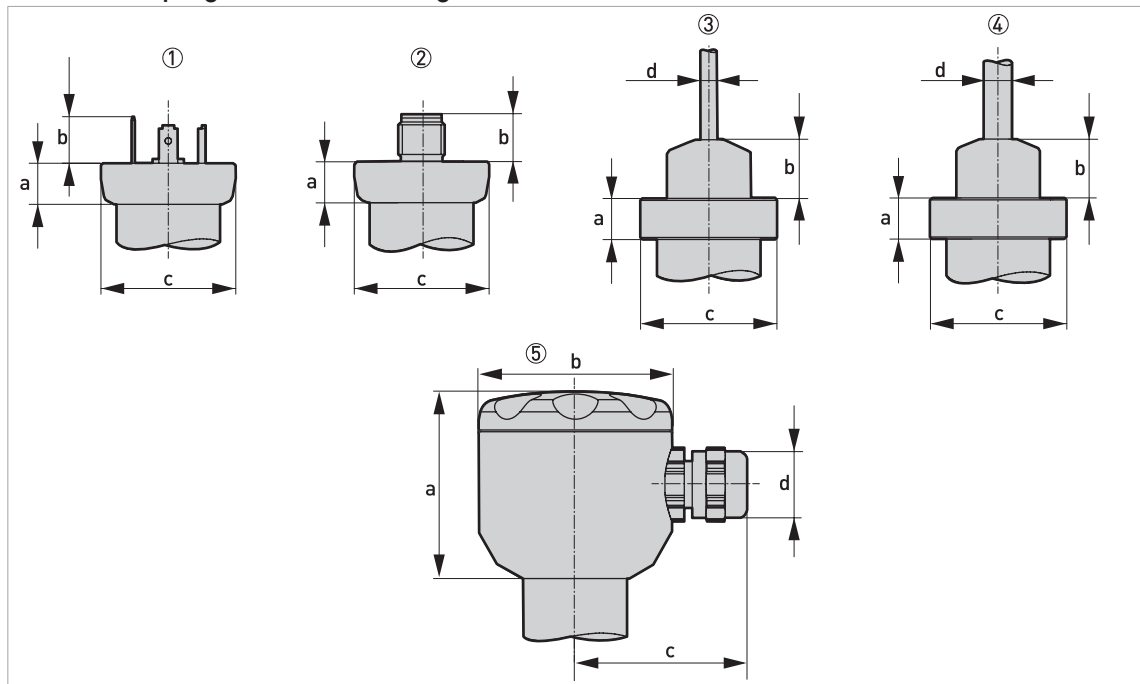

Figure 6-1: Dimensions for connection plug and field housing

- ① ISO 4400 (cable connector is part of delivery)
- ② M12x1 (4-pin)
- ③ Cable output
- ④ Cable output, cable with venting
- ⑤ Field housing

	Dimensions									
	①		②		③		④		⑤	
	[mm]	["]	[mm]	["]	[mm]	["]	[mm]	["]	[mm]	["]
a	10.5	0.4	10.5	0.4	10.5	0.4	10.5	0.4	48	1.9
b	12	0.47	10	0.39	Ø4.3	Ø0.17	7.4	0.29	Ø49.5	Ø1.95
c	Ø34.5	Ø1.36	Ø34.5	Ø1.36	Ø35	Ø1.38	Ø35	Ø1.38	44	1.7
d	-	-	-	-	15	0.59	15	0.59	M12x1.5	

Pressure transmitter with threaded connection

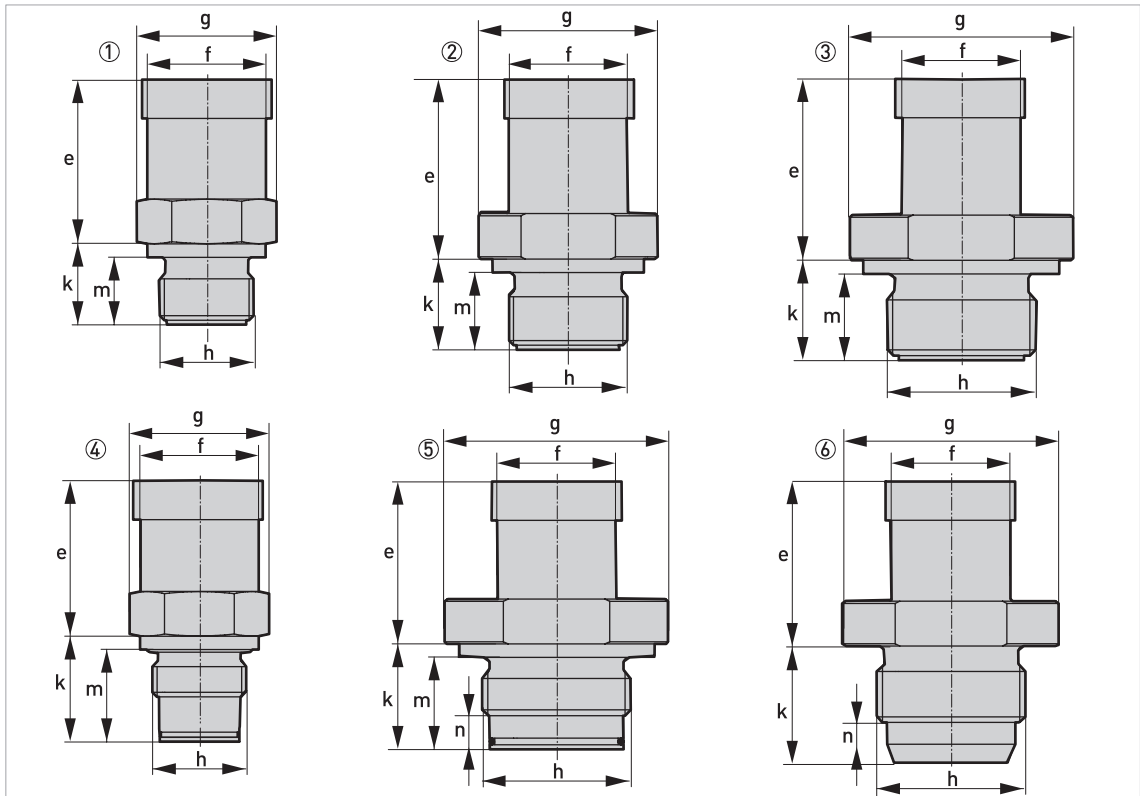

Figure 6-2: Dimensions for pressure transmitter with threaded connection

- ① G 1/2" DIN 3852 flush
- ② G 3/4" DIN 3852 flush
- ③ G 1" DIN 3852 flush
- ④ G 1/2" DIN 3852 flush with radial O-ring
- ⑤ G 1" DIN 3852 flush with radial O-ring
- ⑥ G 1" cone

	Dimensions											
	①		②		③		④		⑤		⑥	
	[mm]	[""]	[mm]	[""]	[mm]	[""]	[mm]	[""]	[mm]	[""]	[mm]	[""]
e	60	2.36	60	2.36	60	2.36	60	2.36	60	2.36	60	2.36
f	∅26.5	∅1.04	∅26.5	∅1.04	∅26.5	∅1.04	∅26.5	∅1.04	∅26.5	∅1.04	∅26.5	∅1.04
g	WS27		WS34		WS44		WS27		WS44		WS41	
h	G 1/2"		G 3/4"		G 1"		G 1/2"		G 1"		G 1"	
k	18	0.71	20	0.79	22	0.87	23.5	0.93	23.5	0.93	26	1.02
m	15	0.59	17	0.67	19	0.75	20.5	0.81	20.5	0.81	-	-
n	-	-	-	-	-	-	-	-	8	-	9	0.35

The entire length of the device is made up of the electrical connection (a), the transmitter housing (e) and the process connection (k).
 With cooling fins (optional) additional 32 mm / 1.26".

Pressure transmitter with cooling fins and hygienic process connections

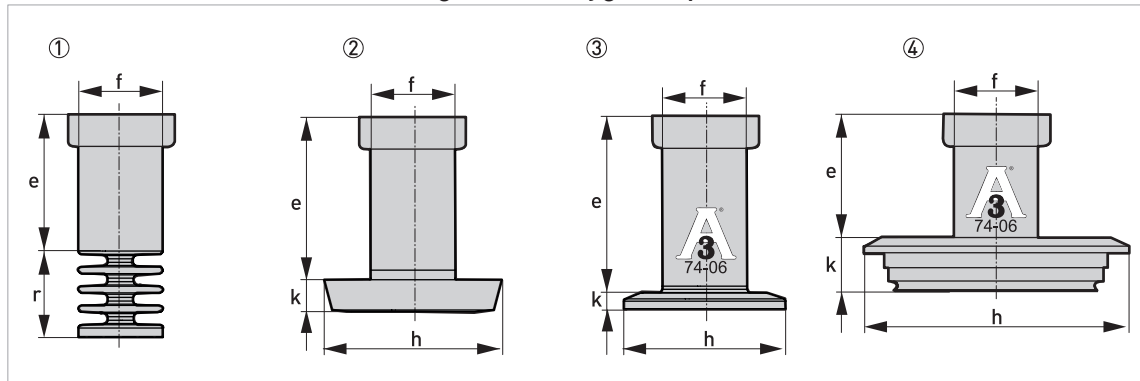

Figure 6-3: Dimensions for pressure transmitter with cooling fins and hygienic process connections

- ① Cooling fins (optional)
- ② Dairy pipe DIN 11851
- ③ Clamp DIN 32678 / ISO 2852, 3-A approved
- ④ Varivent® DN40/50, 3-A approved

	Dimensions							
	①		②		③		④	
	[mm]	["]	[mm]	["]	[mm]	["]	[mm]	["]
e	50	1.97	51	2.01	50	1.97	48	1.89
f	Ø26.5	Ø1.04	Ø26.5	Ø1.04	Ø26.5	Ø1.04	Ø26.5	Ø1.04
h	-	-	DN25: 44 DN40: 56 DN50: 68.5	DN25: 1.7 DN40: 2.2 DN50: 2.7	¾": 25 DN25: 50.5 DN38: 50.5 DN51: 64	¾": 1.0 DN25: 2.0 DN38: 2.0 DN51: 2.5	Ø84	Ø3.3
k	-	-	10	0.39	5	0.2	17	0.67
r	32	1.26	-	-	-	-	-	-

The entire length of the device is made up of the electrical connection (a), the transmitter housing (e) and the process connection (k).

With cooling fins (optional) additional 32 mm / 1.26".

**INFORMATION!**

Other hygienic connections are available on request.

6.3 Measuring ranges

Pressure in bar

Nominal pressure (gauge/abs.)	-1...0	0.10	0.16	0.25	0.40	0.60	1	1.6
Max. working pressure (MWP)	5	0.5	1	1	2	5	5	10
Burst pressure (OPL)	7.5	1.5	1.5	1.5	3	7.5	7.5	15

Nominal pressure (gauge/abs.)	2.5	4	6	10	16	25	40
Max. working pressure (MWP)	10	20	40	40	80	80	105
Burst pressure (OPL)	15	25	50	50	120	120	210

Pressure in psi

Nominal pressure (gauge/abs.)	-14.5...0	1.45	2.32	3.63	5.80	8.70	14.5	23.2
Max. working pressure (MWP)	72.5	7.3	14.5	14.5	29	72.5	72.5	145
Burst pressure (OPL)	108.8	21.8	21.8	21.8	43.5	108.8	108.8	217.6

Nominal pressure (gauge/abs.)	36.3	58.0	87.0	145	232.1	362.6	580
Max. working pressure (MWP)	145	290	580	580	1160	1160	1523
Burst pressure (OPL)	217.6	362.6	725	725	1740	1740	3046





KROHNE product overview

- Electromagnetic flowmeters
- Variable area flowmeters
- Ultrasonic flowmeters
- Mass flowmeters
- Vortex flowmeters
- Flow controllers
- Level meters
- Temperature assemblies
- Pressure transmitters
- Analysis products
- Products and systems for the oil & gas industry
- Measuring systems for the marine industry

Head Office KROHNE Messtechnik GmbH
Ludwig-Krohne-Str. 5
47058 Duisburg (Germany)
Tel.: +49 203 301 0
Fax: +49 203 301 103 89
info@krohne.com

The current list of all KROHNE contacts and addresses can be found at:
www.krohne.com

KROHNE