

USER INSTRUCTIONS

PC-programmable 2-wire Transmitter for Pt100 Input

IPAQ[®] C202/C202X



The user instruction must be read prior to adjustment and/or installation.
All information subject to change without notice.

MEASURE OF SUCCESS



INOR

INOR Process AB, PO Box 9125, SE-200 39 Malmö, Sweden,
Phone: +46 40 312 560, Fax: +46 40 312 570, E-mail: support@inor.se

INOR Transmitter OY, Unikkotie 13, FI-01300 Vantaa, Finland,
Phone: +358 10 421 7900, Fax: +358 10 421 7901, E-mail: jari.stadig@inor.fi

INOR Transmitter GmbH, Duisernplatz 15, 47058 Duisburg, Germany,
Phone: +49 203 86055-300, Fax: +49 203 86055-333, E-mail: info@inor-gmbh.de

KROHNE Temperature Division INOR, 7 Dearborn Road,
Peabody, MA 01960, USA,
Phone: +1 978 826 6900, Fax: +1 978 535 3882, E-mail: inor-info@krohne.com

www.inor.com, www.inor.se



This product should not be mixed with other kind of scrap, after usage.
It should be handled as an electronic/electric device.

MEASURE OF SUCCESS

GENERAL INFORMATION

IPAQ C202 is a low cost, non-isolated, easy-to-use 2-wire temperature transmitter for Pt100 input intended to be used in industrial environment.

IPAQ C202X is the intrinsic safety version of IPAQ C202.

The transmitter is configured from a PC via a USB port, connected via the INOR USB Interface, by using the ConSoft program.

All necessary hardware and software for configuration are included in the ICON Configuration Kit, 70CFGUS001.

DATA (short form)

Input Pt100	3-wire connection
Pt100 (IEC 60751, $\alpha=0.00385$)	-200 to +850 °C / -328 to +1562 °F
Adjustments - Zero	Any value within range limits
Adjustments - Minimum span	20 °C / 36 °F
Output	4-20 mA, temperature linear
Sensor failure indication	Upscale (≥ 21.0 mA) or downscale (≤ 3.6 mA)
NAMUR Compliance	Current limitations and failure currents acc. to NAMUR NE 43
Response time	0.13 to 54 s, adjustable filtering level
Ambient temperature	
Storage and operation	-40 to +85 °C / -40 to +185 °F
Galvanic isolation	No
Power supply	6 to 32 VDC for C202 / 8 to 30 VDC for C202X
Accuracy	Max. of ± 0.1 °C / ± 0.2 °F or ± 0.1 % of span
Error correction	Sensor or System error correction
Runtime counter	Hour counter for elapsed operational time
Mounting	DIN B-head or larger
Terminal	Single/stranded wires Max 1.5 mm ² , Max 0.5 Nm torque
Factory settings	
Input	Pt100 3W, 0 to 100 °C
Output	4 to 20 mA
Filtering level	Response time 0.9 s
Sensor failure indication	Upscale (≥ 21.0 mA)

CONFIGURATION

⚠ The transmitter must not be connected to a computer, when the transmitter is in hazardous area.

For keeping the safety of the internal circuits in the IPAQ C202X, always use Ex-power supply or a zener barrier with limitations according to Ex-data. The communication port may only be connected to the associated ICON Interface.

Before making a configuration of IPAQ C202/C202X you need to do following:

1. Install the configuration software ConSoft and drivers for the INOR USB communication interface on a PC.
2. Connect the USB Interface to a free USB port of your PC and wait for automatic installation of the USB Interface.

Please refer to the installation guide for ConSoft for detailed installation instructions.

Required versions of configuration software:

ConSoft, 3.1.0 or higher
USB Interface, firmware 1.2.06 or higher

Connections:

PC to Interface: through USB type A to USB type B connection cable
Interface to transmitter: Mini USB type B to Mini USB type B cable

Configuration procedure:

1. Connect the transmitter to the PC via the USB Interface, LED indicator "DEV" on the USB Interface becomes green
Configuration can be performed with or without connected power supply to the transmitter.
2. In ConSoft, click on the "Read" button. The software will recognize the connected transmitter and open the configuration window.
3. In the "C202/R202" configuration window you can edit:
 - a. Measuring range in three different engineering units
 - b. Upscale or downscale action at sensor errors
 - c. Compensation for known sensor errors
 - d. TAG-number
4. The selected configuration is downloaded to the transmitter by clicking the button "Write", when the data transfer is complete, the transmitter begins using the new parameters directly.

OUTPUT LOAD DIAGRAM

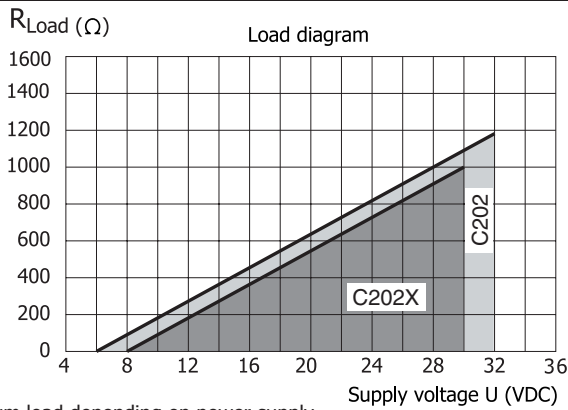

Maximum load depending on power supply

Formula for the max. permissible output load for C202: $R_{Load} = (U-6)/0.022$

Formula for the max. permissible output load for C202X: $R_{Load} = (U-8)/0.022$

IPAQ C202X Ex-DATA

Approval KIWA 15 ATEX 0033X

Approval IECEx KIWA 15.0015X

CE 0539 II 1G Ex ia IIC T6...T4 Ga

Output (current loop)

$U_i \leq 30$ VDC

$I_i \leq 100$ mA

$P_i \leq 900$ mW

$L_i \sim 10$ μ H

$C_i \sim 23.1$ nF

Input (sensor)

$U_o \leq 30$ VDC

$I_o \leq 40$ mA

$P_o \leq 300$ mW

$L_o \sim 10$ mH

$C_o \sim 9$ nF

Control Drawing: 4004491401

LIMITED WARRANTY

INOR Process AB, or any other affiliated company within the Inor Group (hereinafter jointly referred to as "Inor"), hereby warrants that the Product will be free from defects in materials or workmanship for a period of five (5) years from the date of delivery ("Limited Warranty"). This Limited Warranty is limited to repair or replacement at Inor's option and is effective only for the first end-user of the Product. Upon receipt of a warranty claim, Inor shall respond within a reasonable time period as to its decision concerning:

- 1 Whether Inor acknowledges its responsibility for any asserted defect in materials or workmanship; and, if so,
- 2 the appropriate cause of action to be taken (i.e. whether a defective product should be replaced or repaired by Inor).

This Limited Warranty applies only if the Product:

- 1 is installed according to the instructions furnished by Inor;
- 2 is connected to a proper power supply;
- 3 is not misused or abused; and
- 4 there is no evidence of tampering, mishandling, neglect, accidental damage, modification or repair without the approval of Inor or damage done to the Product by anyone other than Inor.

This Limited Warranty is provided by Inor and contains the only express warranty provided.

INOR SPECIFICALLY DISCLAIMS ANY EXPRESS WARRANTY NOT PROVIDED HEREIN AND ANY IMPLIED WARRANTY, GUARANTEE OR REPRESENTATION AS TO SUITABILITY FOR ANY PARTICULAR PURPOSE, PERFORMANCE, QUALITY AND ABSENCE OF ANY HIDDEN DEFECTS, AND ANY REMEDY FOR BREACH OF CONTRACT, WHICH BUT FOR THIS PROVISION, MIGHT ARISE BY IMPLICATION, OPERATION OF LAW, CUSTOM OF TRADE OR COURSE OF DEALING, INCLUDING IMPLIED WARRANTIES OF MERCHANTABILITY AND FITNESS FOR A PARTICULAR PURPOSE. EXCEPT AS PROVIDED HEREIN, INOR FURTHER DISCLAIMS ANY RESPONSIBILITY FOR LOSSES, EXPENSES, INCONVENIENCES, SPECIAL, DIRECT, SECONDARY OR CONSEQUENTIAL DAMAGES ARISING FROM OWNERSHIP OR USE OF THE PRODUCT.

Products that are covered by the Limited Warranty will either be repaired or replaced at the option of Inor. Customer pays freight to Inor, and Inor will pay the return freight by post or other "normal" way of transport. If any other type of return freight is requested, customer pays the whole return cost.

INSTALLATION

IPAQ C202/C202X are designed to fit inside connection heads type DIN B or larger. The larger center hole, dia. 7 mm/0.28 inch, facilitates the pulling through of the sensor leads or an insert tube, greatly simplifying the mounting procedure.

IPAQ C202X must be installed in an enclosure having an Ingress Protection suitable for the actual use but at least IP20
If IPAQ C202X is mounted in a housing (head) made of light metals and installed in hazardous area make sure the content of magnesium (Mg) in the light metal is less than 6%.

If IPAQ C202X is mounted in a housing which is isolated from ground and can be charged to an ignition capable level, then the housing shall be electrostatically grounded when installed in hazardous area.

For keeping the safety of the internal circuits in the IPAQ C202X, always use Ex-power supply or a zener barrier with limitations according to Ex-data.

Connect input, output and power supply acc. to "CONNECTIONS". A convenient way to install the transmitter is to use the INOR mounting kits for in-head and DIN rail mounting. In order to minimize measuring errors make sure the connecting screws are tightened enough.



CAUTION!

For the electrical connection to the in-head transmitter, the maximum torque for screw terminals is 0.5 Nm, for both tightening and untightening the screw.

MOUNTING

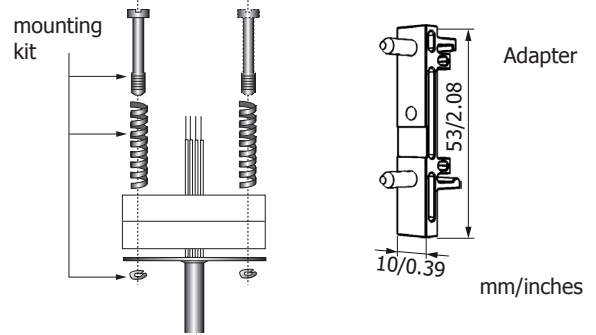

DIMENSIONS

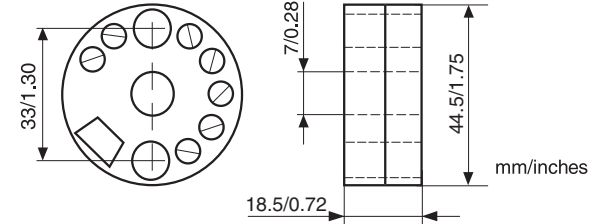

CONNECTIONS

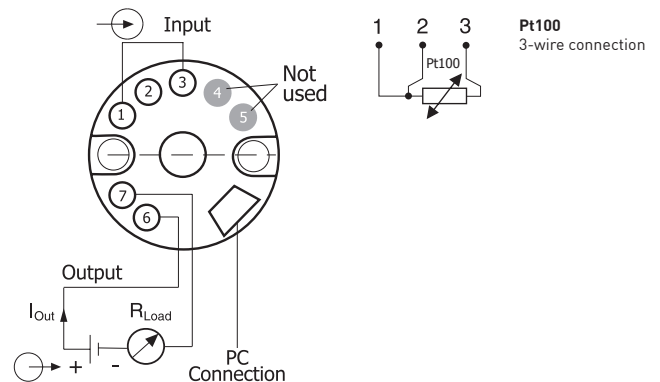

ORDERING INFORMATION

IPAQ C202	70C2020010
IPAQ C202X	70C202X010
ICON Configuration Kit (non-Ex)	70CFGUS001
Head mounting kit	70ADA00017
DIN-rail Adapter	70ADA00015

The transmitters are delivered with either a default factory setting or configured according to customer's specification.