



IPAQ

C520 / C520X
R520 / R520X

HANDBOOK / User Manual



INOR

INOR

SPECIALISTS IN INDUSTRIAL TEMPERATURE MEASUREMENT

Copyright

All rights reserved. Any duplication of this documentation or extracts thereof by any means is prohibited without prior written consent from

Inor Process AB

Subject to change without notice.

Version 6, Copyright 2018 by

Inor Process AB

Travbanegatan 10

SE-213 77 Malmö

Sweden

Tel. +46 (40) 312560

1	Safety instructions	5
1.1	Intended use	5
1.2	Product liability and guarantee	5
1.3	Certifications	5
1.3.1	Certification IPAQ C520X / C520XS	5
1.3.2	Certifications IPAQ R520X / R520XS	6
1.3.3	SIL Certifications	6
1.3.4	EC directive compliances	6
1.4	Manufacturer's safety instructions	6
1.4.1	Notes about the documentation	6
1.4.2	Version history	7
1.4.3	Symbol conventions	7
2	Device description	8
2.1	General description	8
2.2	Identification	9
3	Installation	10
3.1	Installation of the C520/ C520X	10
3.2	Installation of the R520/ R520X	12
4	Electrical connections	13
4.1	Safety instructions	13
4.2	C520/C520X connections	13
4.3	Connection diagram C520	16
4.4	Connection diagram C520X	17
4.5	R520/R520X connections	18
4.6	Connection diagram, R520	22
4.7	Connection diagram, R520X	23
4.8	Cable length	23
5	Operation	25
5.1	C520/R520 in HART network	25
5.2	Configuration of the C520/C520X / R520/R520X	26
5.3	Configuration alternatives	28
5.3.1	Configuration of the 520 series transmitters with ConSoft	29
5.3.2	Configure the 520 series transmitters with handheld communicators FC 375 / FC 475	32
5.3.3	Device management software's	32
5.3.4	Configuration with PACTware	33
5.4	Current output and HART dynamic/device variables	33
5.5	Diagnostic information according to NAMUR NE 107	34
5.6	Sensor failure monitoring according to NE43	36
5.7	Factory configuration and calibration of the C520/C520X / R520/R520X	36
6	Technical data	37
6.1	C520 specifications	37
6.1.1	Technical data	37
6.1.2	Output load diagram	38
6.1.3	Dimensions	38
6.2	C520X specifications	39
6.2.1	Technical data	39
6.2.2	Output load diagram	40
6.2.3	Dimensions	40
6.2.4	Output and input data	41

- 6.2.5 Ambient temperature data for areas with potentially explosive atmospheres41
- 6.3 R520 specifications..... 42
 - 6.3.1 Technical data42
 - 6.3.2 Output load diagram43
 - 6.3.3 Dimensions.....43
- 6.4 R520X specifications..... 44
 - 6.4.1 Technical data44
 - 6.4.2 Output load diagram45
 - 6.4.3 Dimensions.....45
 - 6.4.4 Output and input data46
 - 6.4.5 Ambient temperature data for areas with potentially explosive atmospheres46
- 6.5 RTD and T/C accuracy table for C520/C520X / R520/R520X transmitters 47
- 7 Service..... 48**
 - 7.1 Ordering information..... 48
 - 7.2 Disposal 48
 - 7.3 Maintenance..... 48
 - 7.4 Product liability and guarantee..... 49
 - 7.5 Support 49

1.1 Intended use

The C520 is an intelligent, universal HART-compatible two-wire in-head transmitter for temperature, resistance or voltage measurements in an industrial environment. C520 is also available as an intrinsically safe version for installation in potentially explosive atmospheres. These devices are labeled with the X symbol – C520X – and are approved for use in Zone 0, 1 and 2.

The C520/C520X is intended for installation in a B connection head or larger according to DIN EN 50446.

The R520 is an intelligent, universal HART-compatible two-wire rail-mount transmitter for temperature, resistance or voltage measurements in an industrial environment. The R520 is also available as an intrinsically safe version for installation in potentially explosive atmospheres. These devices are labeled with the X symbol – R520X – and are approved for use in Zone 1 and 2 while the input can be connected to Zone 0.

The R520/R520X is intended for installation on a 35 mm top-hat rail according to EN 60715.



ATTENTION!

Responsibility for the use of the device with regard to suitability, intended use and area of application lies solely with the user.

The manufacturer shall not be liable for damage resulting from improper use or use for other than the intended purpose.

1.2 Product liability and guarantee

Use of the product for other than the intended purpose or improper installation, and operation may lead to loss of the guarantee. The guarantee shall likewise be void if the device is damaged or its function otherwise impaired.

Inor Process AB hereby guarantees that the product will be free of material and workmanship defects for a period of five (5) years from the date of delivery ("limited guarantee"). This limited guarantee refers to repairs or exchanges, and is only valid for the first end user of the product. The "General conditions of sale" forming the basis of the purchase contract are also applicable.

1.3 Certifications

1.3.1 Certification IPAQ C520X / C520XS

Control drawing:	88DRW00025
EC: ATEX approval	KIWA 14 ATEX 0003X CE 0539  II 1G Ex ia IIC T6...T4 Ga
IECEX :	IECEX KIWA 14.0001X Ex ia IIC T6...T4 Ga

1.3.2 Certifications IPAQ R520X / R520XS

Control drawing:	88DRW00050
EC: ATEX approval	KIWA 14 ATEX 0023X CE 0539  II 2(1)G Ex ia [ia Ga] IIC T6...T4 Gb
IECEX :	IECEX KIWA 14.0010X Ex ia [ia Ga] IIC T6...T4 Gb

1.3.3 SIL Certifications

Compliance: Functional safety acc. to IEC 61508:2010. Certificate No. SC0266-13, issued by SP Technical Research Institute of Sweden.

Safety Integrity Level: SIL 2

For details, we refer to the separate document: SIL – Safety Manual.

1.3.4 EC directive compliances

The measuring device complies with the statutory requirements of the following EC directives: EMC Directive 2004/108/EC (until April 19th, 2016) and EMC Directive 2014/30/EU (from April 20th, 2016)

ATEX Directive 94/9/EC (until April 19th, 2016) and ATEX Directive 2014/34/EU (from April 20th, 2016)

The manufacturer's Declaration of Conformity can be viewed and downloaded from INOR website www.inor.com.

Select "Download and Documentation".

Inor Process AB certifies successful testing of the product by applying the CE mark.

1.4 Manufacturer's safety instructions

The measuring device has been built and tested in accordance with the current state of the art, and complies with the relevant safety standards.

However, dangers may arise from improper use or use for other than the intended purpose.

For this reason, observe all of the safety instructions in this document carefully.

1.4.1 Notes about the documentation

In addition to the safety rules and industrial safety regulations in this documentation, national and regional safety rules and industrial safety regulations must also be observed.

1.4.2 Version history

The following table gives an overview about the hardware and software history and compatibility with its configuration tool and documentation.

Hardware version	Production order no.	IPM software	OPM software	ConSoft version	User Manual
≤ 9	C520: ≤ 571029873 R520: ≤	01.01.03xxx	01.01.04xxx	2.0.0.8	≤ version 2
≥ 11	C520: ≥ 571030029 R520: ≥	01.02.02xxx	≥01.02.02xxx	≥2.0.0.8	≥ version 4

1.4.3 Symbol conventions

For greater clarity, the following symbols are used in this documentation:



DANGER!, WARNING!, ATTENTION!, CAUTION!

This symbol indicates general dangers.

All warnings must always be observed. Even partial failure on your part to observe them can lead to serious damage to health, damage to the device or to the user's system components.



DANGER!

This symbol is used to identify dangers when working with electric current.

Work on the device's electrical and electronic components may only be performed by qualified personnel with the appropriate training.



DANGER!

This symbol indicates dangers in areas with potentially explosive atmospheres, for example those which may arise during installation and operation of explosion-proof devices.

Special regulations apply for use in areas with potentially explosive atmospheres; these must always be observed in order to ensure safe use in such areas. Installation, set-up, operation and maintenance of the device may only be performed by qualified persons with training in explosion protection.



Important note!, Note!, Information!

This symbol identifies important notes and information for working with the device.



Legal note!

This symbol identifies references to legal and normative regulations.



Action

This symbol identifies all instructions for actions; the actions must be performed by the user in the specified sequence.



Effect

This symbol identifies all of the important effects of the previous actions.

2.1 General description

The C520/C520X / R520/R520X are intelligent two-wire universal transmitters for measurement with up to two user programmable channels in single, differential, average, minimum or maximum mode.

The C520/C520X / R520/R520X are intended for:

- Temperature measurements with single or dual resistance thermometers
- Temperature measurements with single or dual thermocouples
- Temperature measurements with one resistance thermometers and one thermocouple
- Temperature difference measurements with resistance thermometers
- Measurements with potentiometers
- Voltage measurements in a range -10...1000 mV

To increase reliability and stability of the system, C520/R520 transmitters have dual sensor inputs.

The dual sensor inputs enable new safety features such as sensor redundancy and sensor drift monitoring.

C520S/C520XS/R520S/R520XS are reviewed by exida according to IEC 61508-2:2010 and by SP for full assessment according to IEC 61508-2 and -3:2010 for use in SIL 2 rated Safety Instrumented Systems (SIS). For safety instructions see the safety manual.

The C520 and R520 are the standard versions for use in safe (non-hazardous) areas.

The C520X and R520X are Intrinsically Safe versions for use in areas with potentially explosive atmospheres, Zone 0 (only C520X), 1 and 2.

The C520 and C520X are designed for installation in a B connection head according to DIN EN 50446 or larger.

The R520 and R520X are designed for installation on a 35 mm top-hat rail according to EN 60715.

The two-wire universal C520/C520X / R520/R520X transmitters are HART® 5 and 6-compatible. Configuration of the C520/R520 transmitters is possible with:

- HART® 5 and 6 protocol via 4...20 mA output circuit
- HART® 5 and 6 handheld terminal
- The graphic user interface DTM
- The third part PC software with a FSK modem for HART® 5 and 6 communication
- PC configuration software ConSoft with PC Configuration Kit - ICON

The PC configuration software ConSoft is used for configuration, display and documentation. The current ConSoft version is available for downloading on our website www.inor.com.

2.2 Identification

The transmitter can be identified by the information in the label, see below.

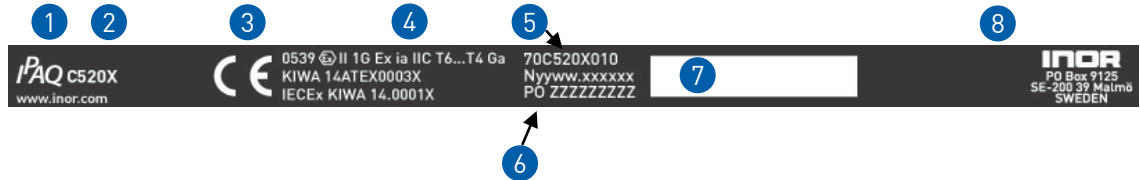

Figure 1: Peripheral label - IPAQ C520X can be used in Category 1, 2 and 3, Zones 0, 1 and 2

1	Family name
2	Model name of transmitter
3	CE mark (EC conformity)
4	Technical data (see Chapter 1.3.1 in this user manual for information)
5	Ordering code (Part No)
6	Serial number and batch number
7	Printable field, sensor configuration
8	Manufacturer of transmitter and address

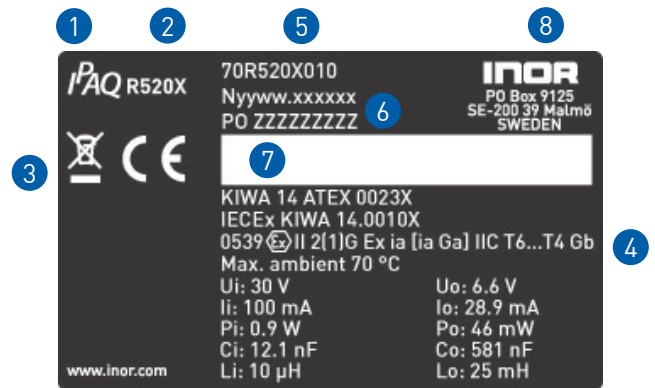

Figure 2: Peripheral label - IPAQ R520X can be used in Category 2 and 3, Zones 1 and 2, and may be connected to a sensor installed in Category 1, Zone 0.

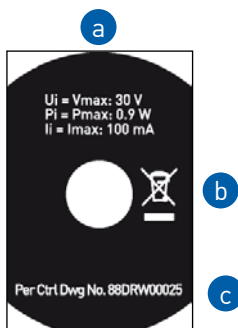

Figure 3: Bottom label - IPAQ C520X

a	Electrical data for max input to transmitter (see Chapter 6.2.4 user manual for information)
b	An electronic/electric device waste marking (see Chapter 7.2 user manual for information)
c	Control drawing number

3.1 Installation of the C520/ C520X

The C520/C520X is intended for installation in DIN B connection heads or larger. The large $\varnothing 7$ mm / 0.28" center hole (see Chapter 6.1.3) facilitates the electrical connection of the measurement sensor and the installation.

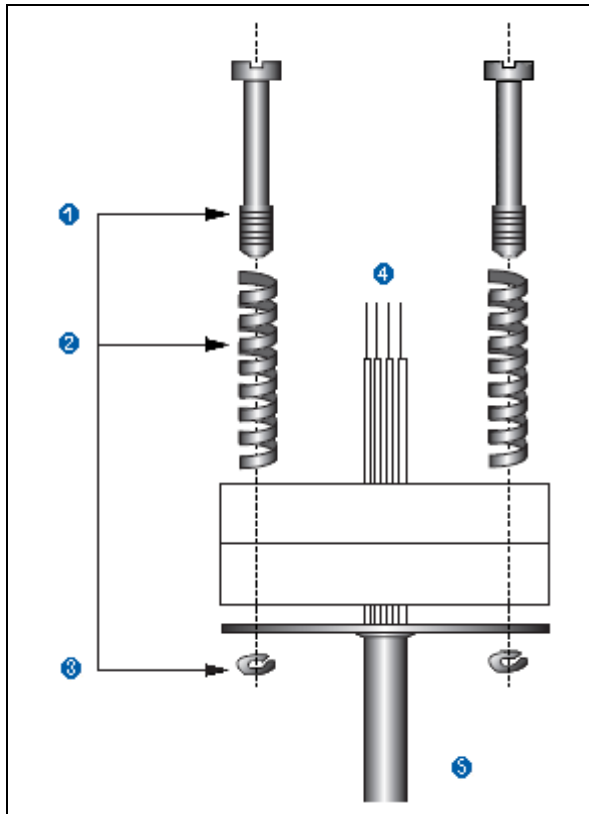

Figure 4: Connection head installation kit 70ADA00017

1	Screw, M4
2	Spring
3	Lock washer
4	Pt100
5	Protective tube



ATTENTION!

In potentially explosive areas, the C520X must be used. The transmitter C520X must be supplied by an intrinsically safe power supply unit or Zener barrier placed outside of the potentially explosive zone.



ATTENTION!

The C520X transmitter must be installed in a housing with the protection rating IP20 or better according to EN 60529 / IEC 60529.

When mounted in a zone 0 location (which is allowed for a 1 G (Ga) equipment), precautions shall be taken into account when the enclosure material is light metal (protect against impact and friction that can cause ignition capable sparks) or non-conductive non-metallic material (protection against electrostatic discharge).



CAUTION!

For the electrical connection to the in-head transmitter, the maximum torque for screw terminals is 0.5 Nm, for both tightening and untightening the screw.



- **IMPORTANT NOTE!**

- *Ambient temperature considerations*
- *The C520/C520X temperature transmitter has been developed for an ambient temperature range from -40 to 85°C (-40 to +185°F). Please also note that the ambient temperature is also dependent on the temperature category in Section 6.2.5, Ex data of the ambient temperature.*

The process temperature is also transferred to the transmitter housing via the protective tube. If the process temperature is close to or exceeds the maximum specified process temperature, then the temperature in the transmitter housing can rise above the maximum permissible ambient temperature. Always check that the ambient temperature where the transmitter is installed is always within the permissible range. One way to decrease heat transfer via the protective tube is to make the protective tube longer or in general to install the transmitter farther away from the heat source. The same safety measures can be taken if the temperature is below the specified minimum temperature.

3.2 Installation of the R520/ R520X

The R520 / R520X transmitter is intended for installation on a 35 mm top-hat rail according to EN 60715.

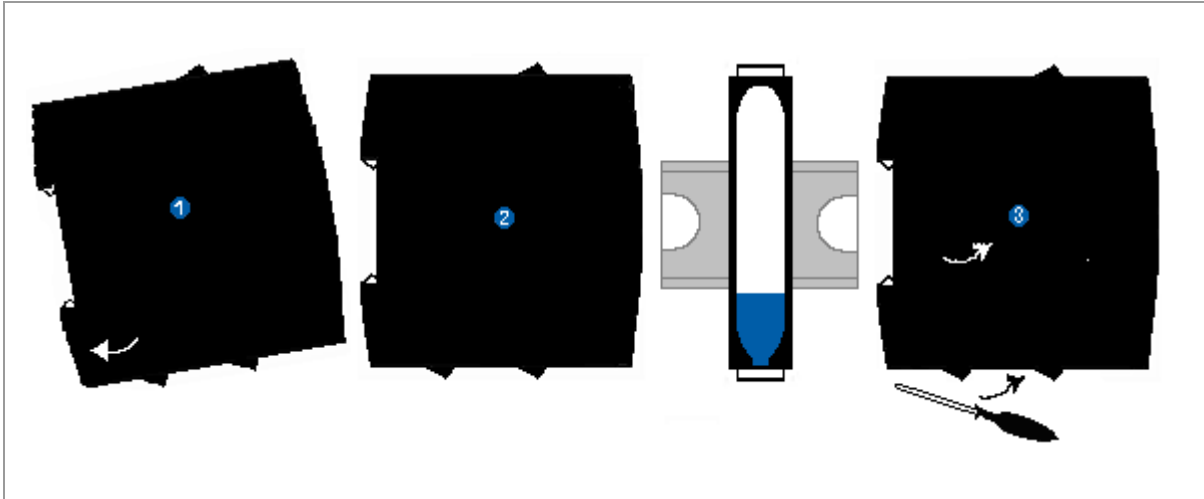

Figure 5: Rail installation

1	Fix the upper part of the transmitter onto the rail.
2	Press the lower part of the transmitter against the rail.
3	To remove the transmitter, bend the locking device using a small screwdriver. Carefully pull the transmitter in the forward direction.



ATTENTION!

In potentially explosive areas, the R520X must be used.

The transmitter R520X can be installed in potentially hazardous area Zone 1 and 2 and the input may be connected to Zone 0. R520X must be supplied by an intrinsically safe power supply unit or Zener barrier placed outside of the potentially explosive zone.

The R520X transmitter must be installed in a housing with the protection rating IP20 or better according to EN 60529 / IEC 60529.

The R520/R520X temperature transmitter has been developed for an ambient temperature range from -20 to 70°C (-4 to +158°F). Please also note that the ambient temperature is also dependent on the temperature category in Section 6.4.5, Ex data of the ambient temperature.



CAUTION!

For the electrical connection to the in-head transmitter, the maximum torque for screw terminals is 0.5 Nm, for both tightening and untightening the screw.

4.1 Safety instructions

**ATTENTION!**

Any work on the device may only be performed by trained and qualified personnel. The regional industrial safety and other safety regulations must always be observed.

**ATTENTION!**

Observe the national regulations for electrical installations!

Any work on the electrical connections may only be performed in the de-energized state.

Observe the voltage specifications on the rating plate!

Observe the relevant installation regulations in your country!

The transmitter is protected against polarity reversal. No damage will occur to the device if the polarity of the supply voltage is switched. The output will then indicate 0 mA.

**ATTENTION!**

When connecting devices with an Ex certificate, the corresponding chapters and the instructions in this manual must be observed.

The transmitter must be supplied with an intrinsically safe power supply unit or Zener barrier outside of the potentially explosive zone.

The Communication port (USB connection) may only be connected to the associated ICON Interface if the temperature transmitter is outside the hazardous area and with no sensor connected to it that is in the hazardous area.

For the applicable ambient temperature range, refer to section 6.2.5 respectively 6.4.5.

The transmitter shall be mounted into a suitable enclosure that provides a degree of protection of at least IP20.

4.2 C520/C520X connections

The input and output signals and the power supply must be connected in accordance with the following illustrations. The transmitter is easy to install with the Inor connection head installation kit (see ordering information Chapter 7.1). To avoid measuring errors, all cables must be connected properly and the screws tightened correctly.

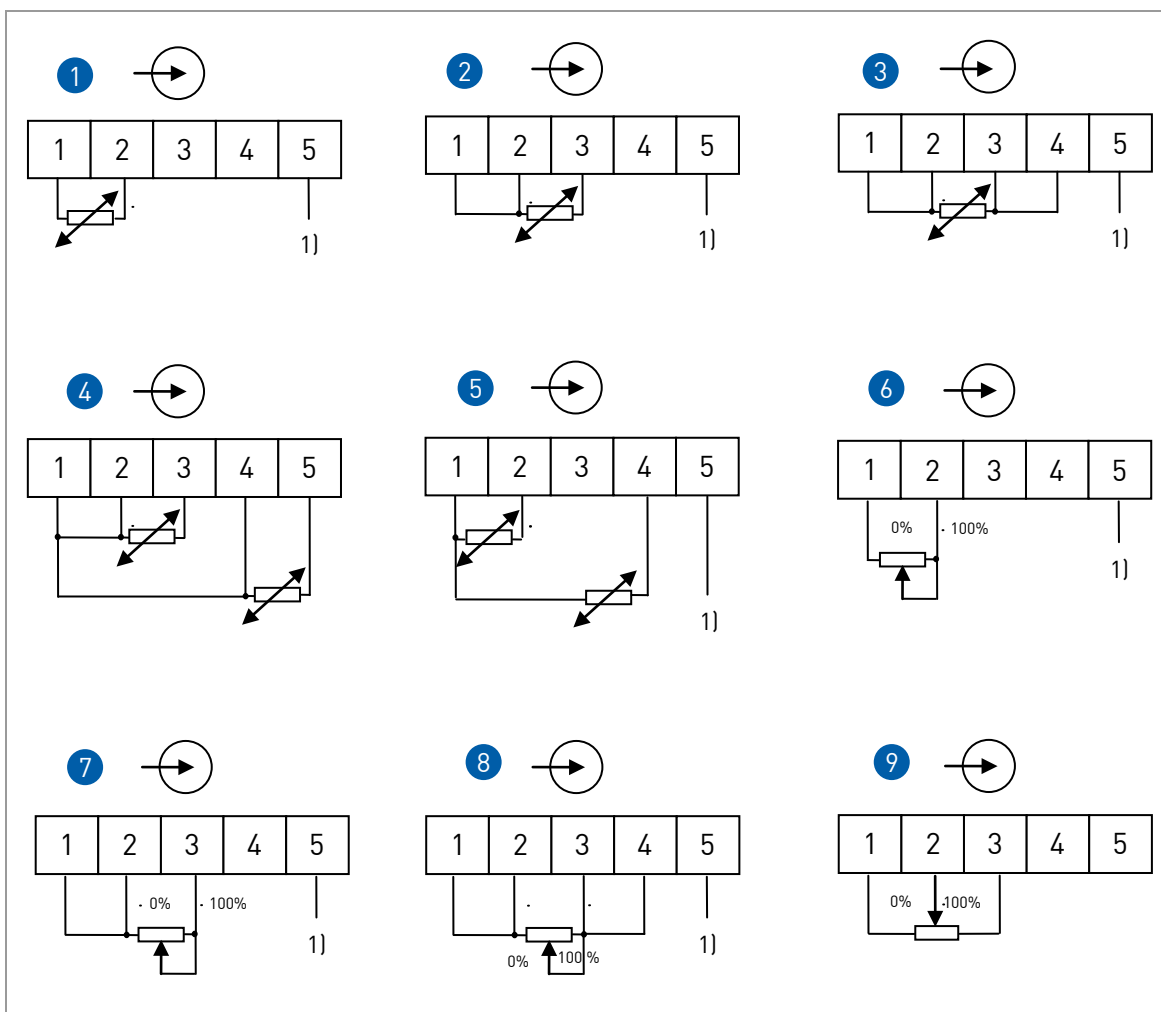

Figure 6: Installation diagram, RTD resistance and potentiometer measurement C520/C520X

1	RTD, 2-wire connection
2	RTD, 3-wire connection
3	RTD, 4-wire connection
4	RTD, 2 x 3-wire connection
5	RTD, 2 x 2-wire connection
6	Resistance, 2-wire connection
7	Resistance, 3-wire connection
8	Resistance, 4-wire connection
9	Potentiometer, 3-wire connection

1) SmartSense wire

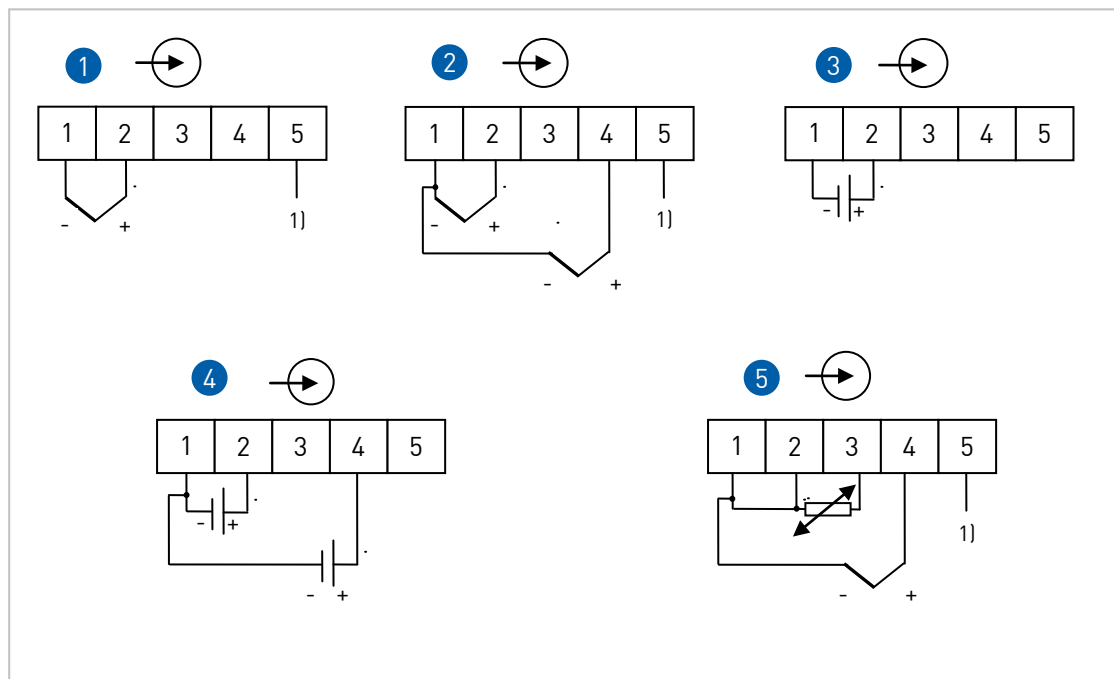

Figure 7: Installation diagram, thermocouple and voltage measurement C520/C520X

1	Thermocouple
2	Thermocouple, dual sensor elements
3	Voltage
4	Voltage, dual voltage sources
5	Combined 3-wire RTD element and thermocouple (RTD also used for remote CJC)

1) SmartSense wire

4.3 Connection diagram C520

**ATTENTION!**

To enable HART communication, the output circuit must have an output load of at least 250 Ω.

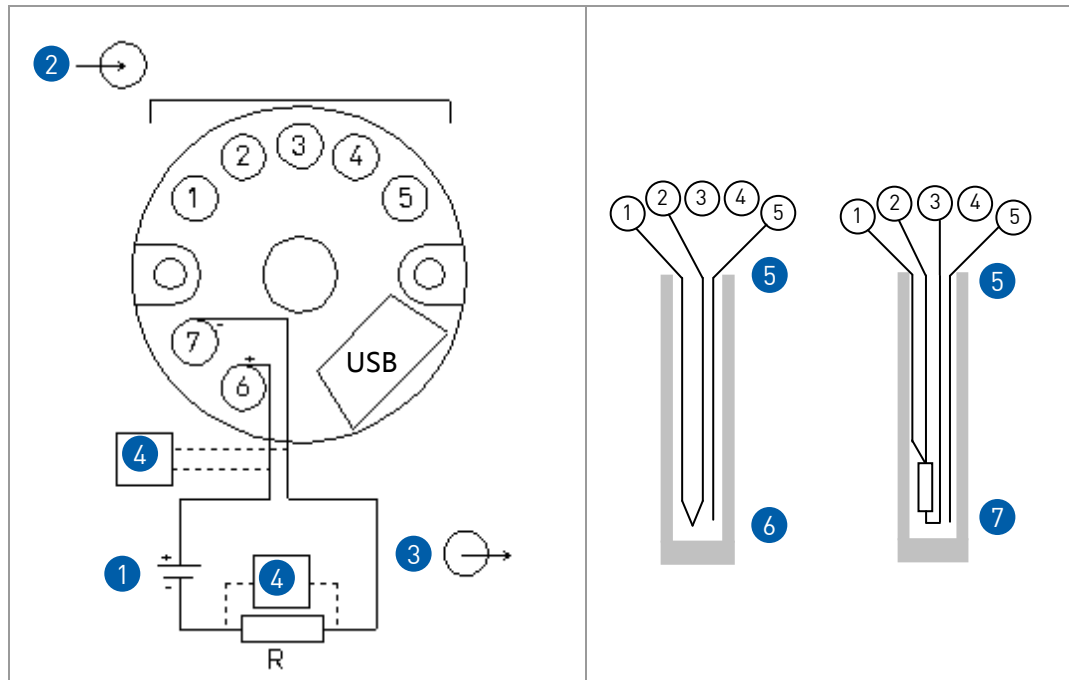

Figure 8: C520 connection

1	Voltage supply 10...36 VDC (terminals 6, 7)
2	Input
3	Output
4	Modem
5	SmartSense temperature sensor
6	Thermocouple
7	Pt100 3 wire connection

**NOTE!**

The HART modem is connected parallel to the output load or parallel to the output of the transmitter (see Figure 7).

4.4 Connection diagram C520X

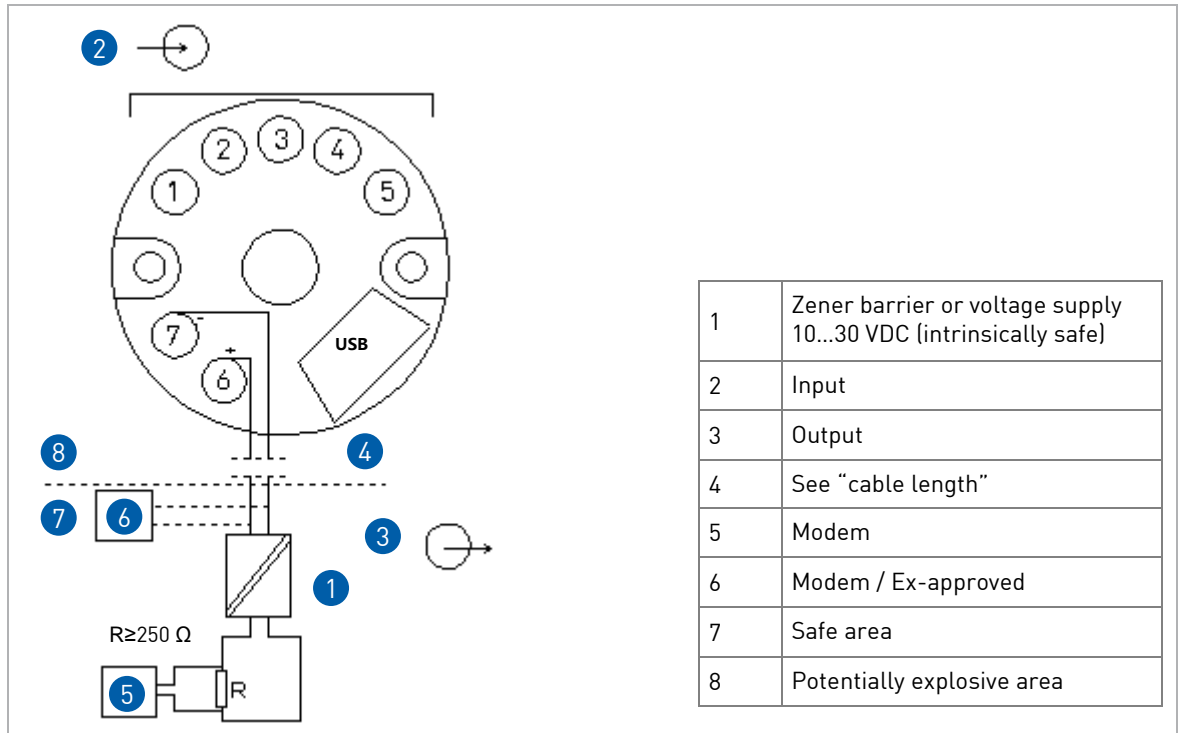

Figure 9: C520X connection

**NOTE!**

The HART modem is connected parallel to the output load or parallel to the output of the transmitter (see Figure 8).

**ATTENTION!**

The transmitter may be operated in areas with potentially explosive atmospheres if the voltage supply is ensured by means of an appropriate power supply unit or a Zener barrier!

**ATTENTION!**

In potentially explosive areas only Ex approved HART modems may be used. The safety instructions for operation in potentially explosive areas must be observed.

**ATTENTION!**

In order to ensure reliable HART communication with C520X, the maximum cable length of the output circuit must be observed (see Chapter 4.8).

4.5 R520/R520X connections

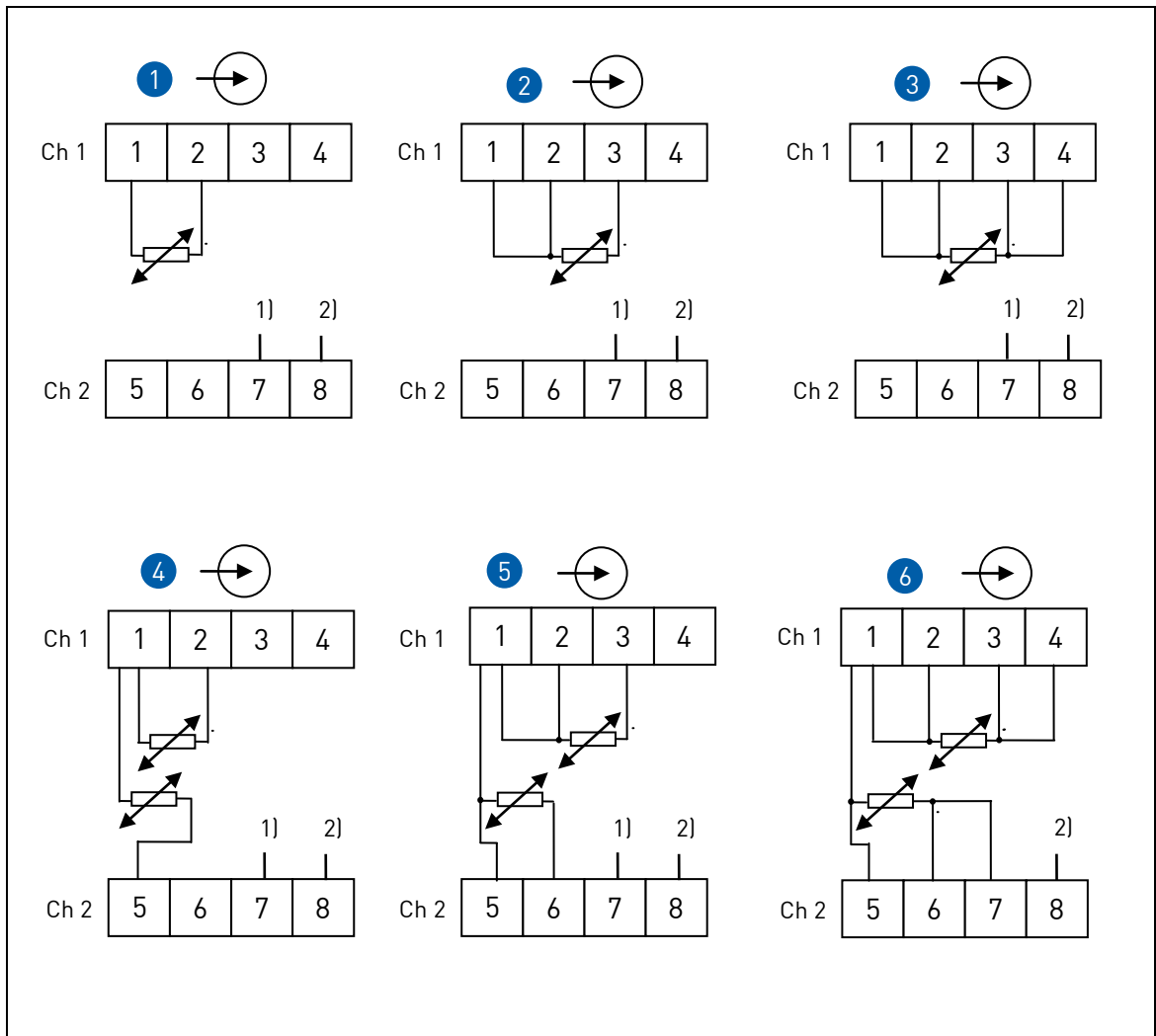

Figure 10: Installation diagram, RTD connections for R520/R520X

- 1) SmartSense wire
- 2) GND (input cable screen)

1	RTD, 2-wire connection
2	RTD, 3-wire connection
3	RTD, 4-wire connection
4	RTD, 2 x 2-wire connection
5	RTD, 2 x 3-wire connection
6	RTD, 2 x 4-wire connection

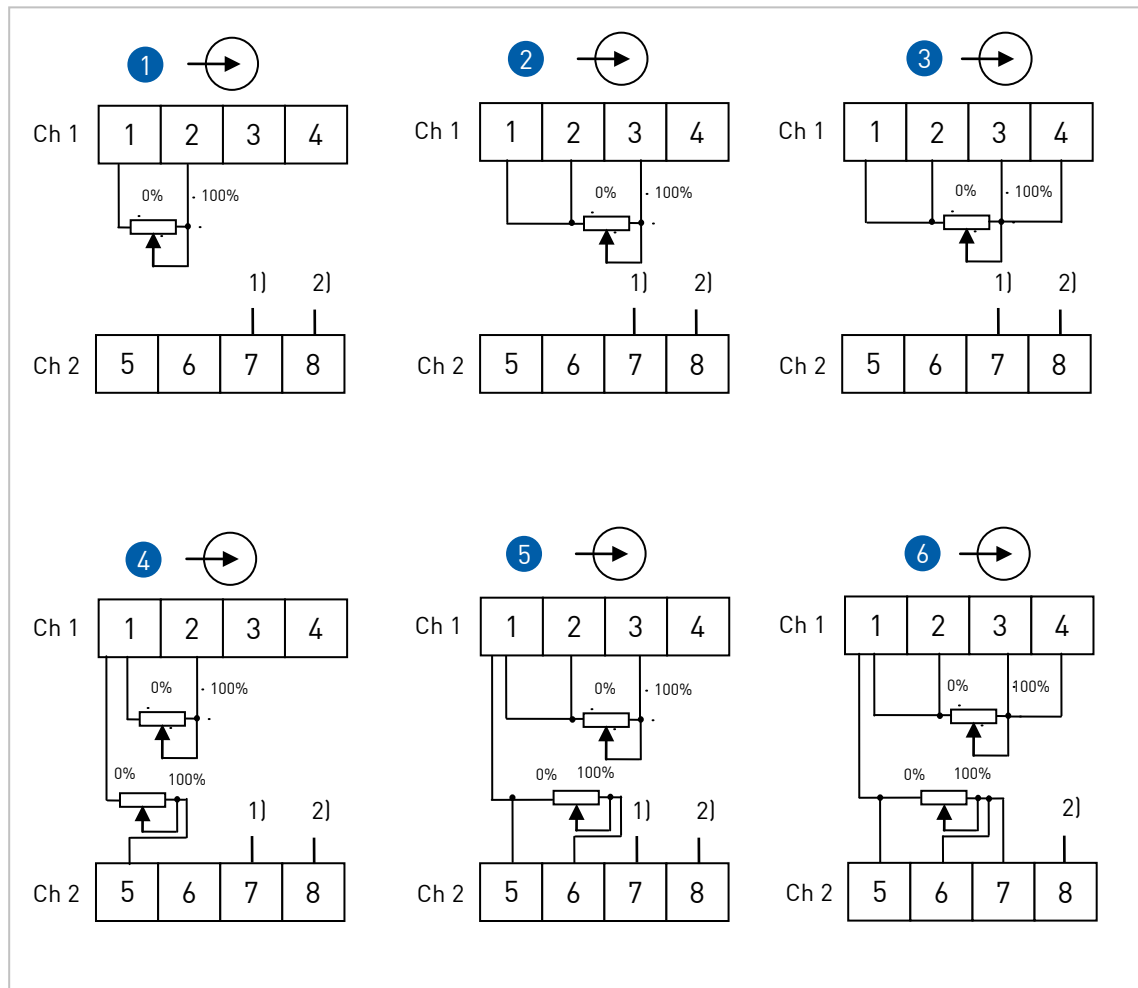

Figure 11: Installation diagram, resistance connections for R520/R520X

- 1) SmartSense wire
- 2) GND (input cable screen)

1	Resistance, 2-wire connection
2	Resistance, 3-wire connection
3	Resistance, 4-wire connection
4	Dual resistance, 2-wire connection
5	Dual resistance, 3-wire connection
6	Dual resistance, 4-wire connection

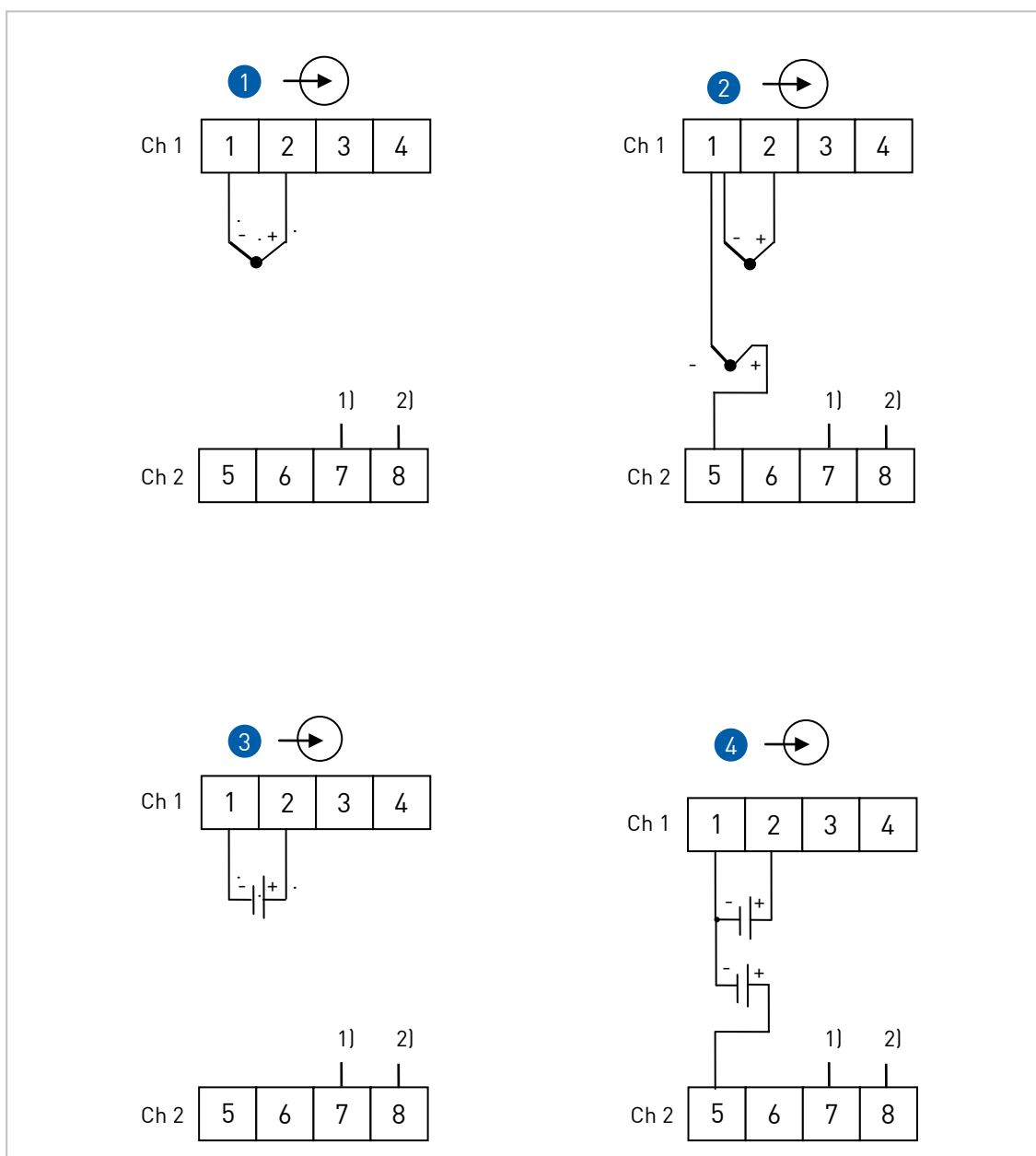

Figure 12: Installation diagram, thermocouple and voltage connections for R520/R520X

- 1) SmartSense wire
- 2) GND (input cable screen)

1	Thermocouple
2	Thermocouple, dual sensor elements
3	Voltage
4	Voltage, dual sensor elements

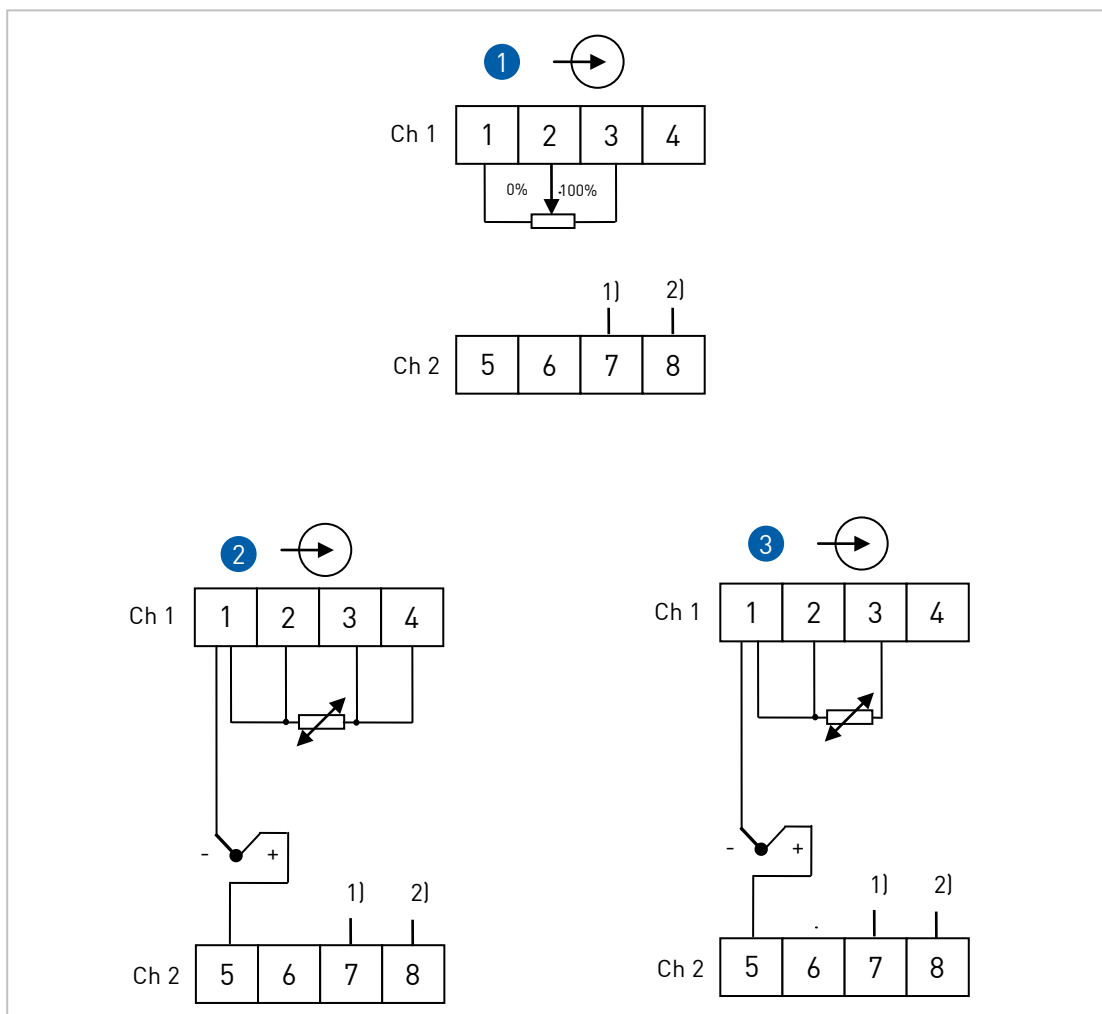

Figure 13: Installation diagram, potentiometer and combined thermocouple and RTD connections for R520/R520X

- 1) SmartSense wire
- 2) GND (input cable screen)

1	Potentiometer 3-wire connection
2	Combined 4-wire RTD element and thermocouple (RTD also used for remote CJC)
3	Combined 3-wire RTD element and thermocouple (RTD also used for remote CJC)

4.6 Connection diagram, R520

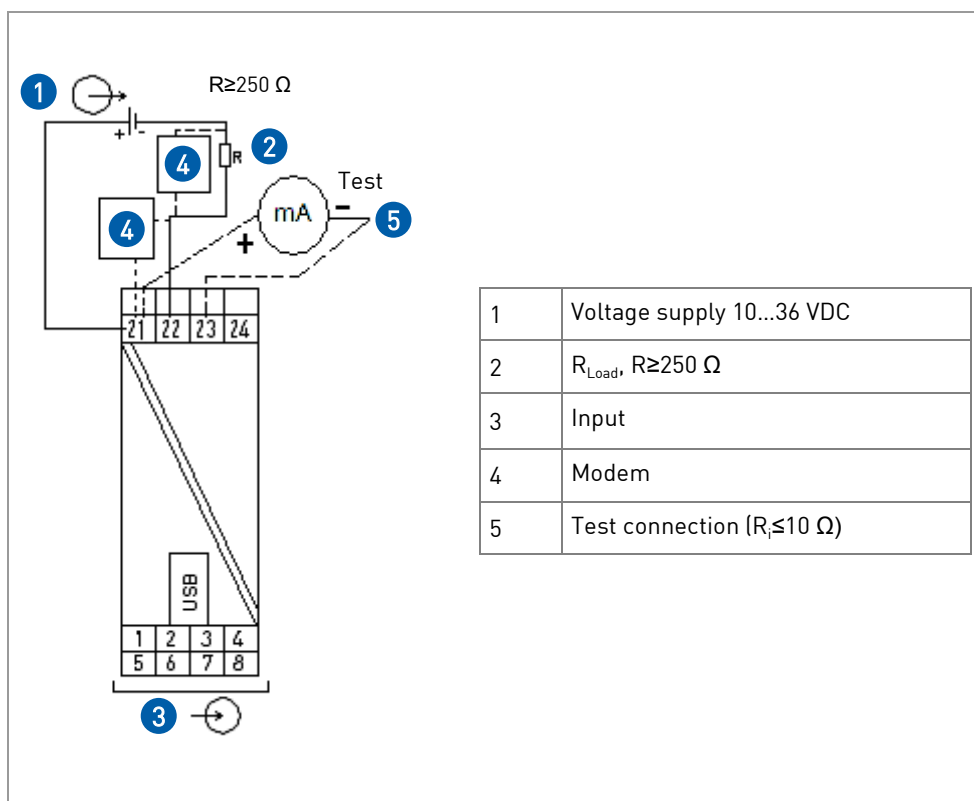

Figure 14: R520 connection diagram

**NOTE!**

The HART modem is connected parallel to the output load or parallel to the output of the transmitter (see Figure 13).

4.7 Connection diagram, R520X

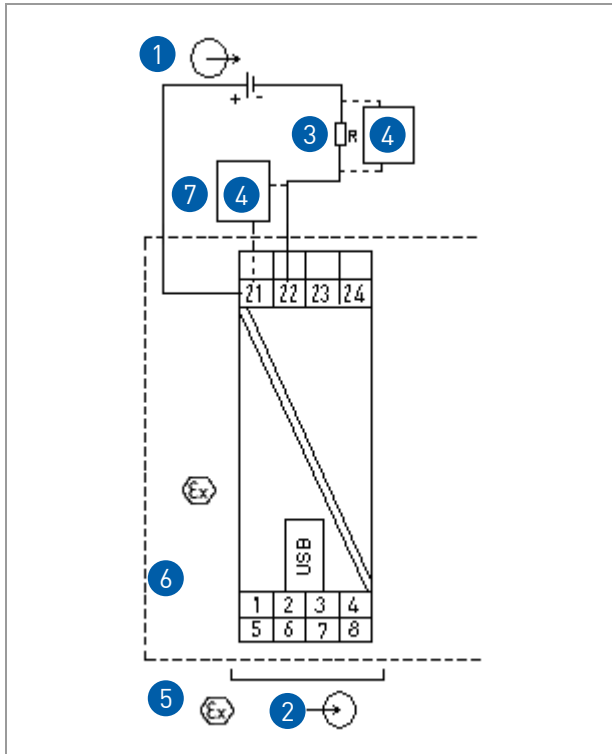

Figure 15: R520X connection diagram

1	Voltage supply 10...30 VDC (intrinsically safe - terminals 21, 22)
2	Input (intrinsically safe)
3	R_{Load} (intrinsically safe)
4	Modem / Ex (intrinsically safe)
5	Classified hazardous area (potentially explosive area e.g. Zone 0, 1 or 2)
6	Classified hazardous area (potentially explosive area e.g. Zone 1 or 2)
7	Safe area

4.8 Cable length

In order to ensure reliable HART communication with C520/R520, the maximum cable length of the output circuit must be observed.

**ATTENTION!**

In the Ex version, please note that the maximum cable length is determined by the resistance, the inductance and the capacitance of the cable. The total capacitance and inductance of the cable must be within the limits for the transmitter described in the Ex certificate.

To calculate the maximum cable length for the output circuit, determine the total resistance of the output loop (load resistance plus the approximate cable resistance). Find out the capacitance of the cable being used. In the tables below you can find the maximum cable length based on the typical values for 1 mm² cables. CN is the abbreviation for Capacitance Number which is multiple of 5000 pF present in the device.

Field device	Cable insulation		
	PVC	Polyethylene	Polyethylene foam
1 (CN = 1)	600 m	1100 m	2000 m
10 multi-drop (CN = 1)	500 m	900 m	1600 m
10 multi-drop (CN = 4,4)	85 m	150 m	250 m

Table 1: Maximum length for typical 1 mm² cables

Insulation	Capacitance
PVC	300...400 pF/m
Polyethylene	150...200 pF/m
Polyethylene foam	75...100 pF/m

Conductors			Resistance (both conductors in serie)
Area	Diameter	AWG	
2.0 mm ²	1.6 mm	14	17 Ω/km
1.3 mm ²	1.3 mm	16	28 Ω/km
1.0 mm ²	1.15 mm	17	36 Ω/km
0.8 mm ²	1.0 mm	18	45 Ω/km
0.5 mm ²	0.8 mm	20	70 Ω/km
0.3 mm ²	0.6 mm	22	110 Ω/km
0.2 mm ²	0.5 mm	24	160 Ω/km

Table 2: Cable parameters

For multiple connections (multi-drop see the Figures 16), the following formula shall be used

$$L = \frac{65 \times 10^6}{R \times C} \times \frac{(C_n \times 5000 + 10000)}{C}$$

L:	Cable length (m)
R:	Load resistance (incl. The resistance of any Zener barrier) + cable resistance (Ω)
C:	Cable capacitance/meter (pF/m)
Cn:	Number of C520/R520 transmitters in the loop

Cable length can be changed to ft. The capacitance has to be specified in pF/ft.

5.1 C520/R520 in HART network

Communication mode supported by C520/R520 transmitters is a master-slave mode.

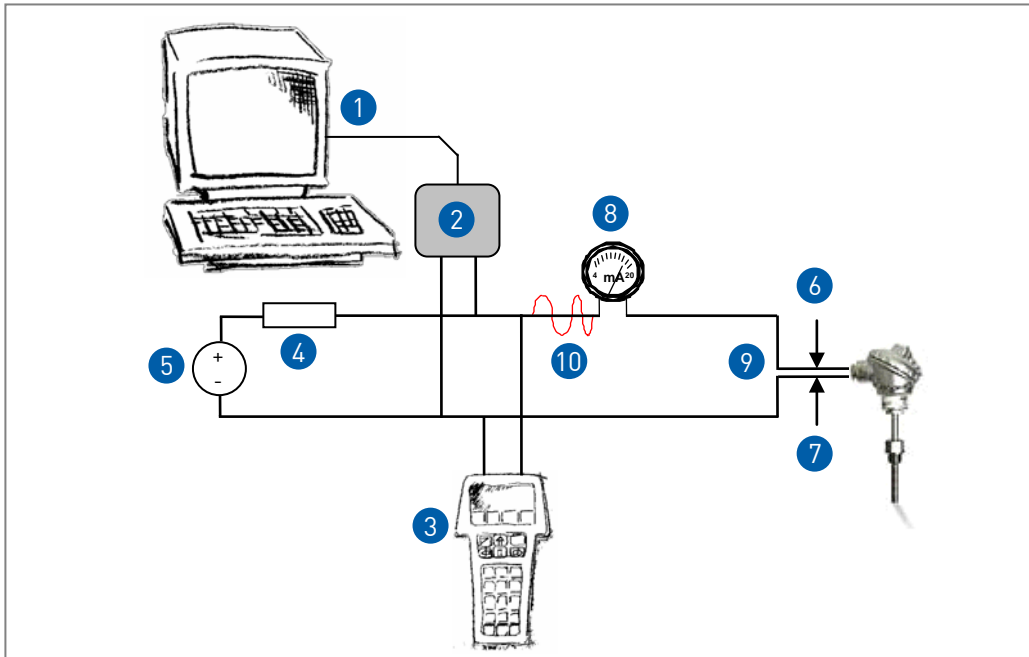

Figure 16: C520 point-to-point analog / digital mode

1	Primary master
2	HART modem
3	Secondary master
4	Load $\geq 250 \Omega$
5	DC power supply
6	Terminal 6
7	Terminal 7
8	Milliamperemeter Load $\geq 250 \Omega$
9	4...20 mA
10	HART

Figure 16 shows a point-to-point connection between the C520/R520 and the HART master equipment. The device's current output may be active or passive.

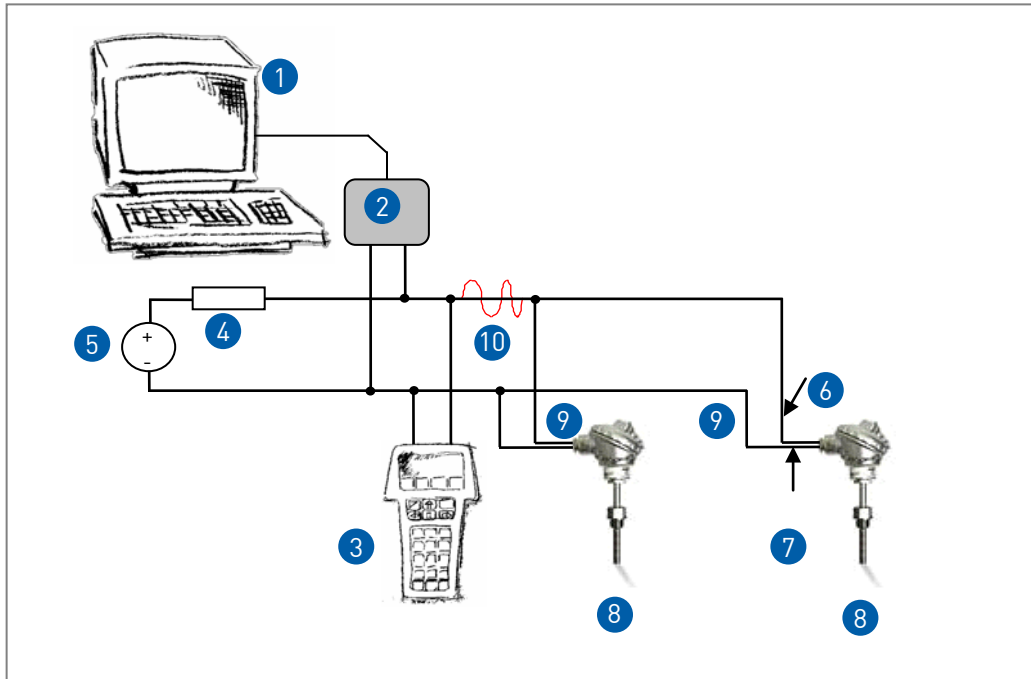

Figure 17: C520 in a multipoint connection (multi-drop mode) with up to 63 devices in parallel

1	Primary master
2	HART modem
3	Secondary master
4	Load $\geq 250 \Omega$
5	DC power supply
6	Terminal 6
7	Terminal 7
8	C520 or R520 loop current mode disabled up to 63 slaves can be connected
9	4 mA
10	HART

Figure 17 shows a multipoint connection (multi-drop) with up to 63 devices (C520/R520 or other HART equipment) in parallel. The device's current outputs must be passive.

Burst mode is not supported.

5.2 Configuration of the C520/C520X / R520/R520X



ATTENTION!

Only an Ex approved HART modem located in safe area may be connected to a transmitter placed in potentially explosive area.

In the table below are the factory settings of the C520/C520X / R520/R520X transmitters. The transmitters are delivered with either a factory settings or configured according to customers' specifications.

Menu	Designation	Parameter	Factory setting
Device Root menu			
-> Sensors	-> Channel 1	Type of sensor 1	RTD Pt100 $\alpha=0.003850$
		Number of wires	4
		PV Lower range value	0
		PV Upper range value	100
		Digital units	°C
		Lock Code	Unlocked
		Damping value	4 s
		Line frequency	50/60 Hz
		Isolation Resistance monitoring	Off
		Sensor Break (Off/Downscale/Upscale)	Upscale
		Sensor Short circuit (Off/Downscale/Upscale)	Upscale
		Sensor Drift (Off/Downscale/Upscale)	Off
	-> Channel 2	Type of sensor 2	None
		Number of wires	
		PV Lower range value	
		PV Upper range value	
		Digital units	°C
		Lock Code	Unlocked
		Damping value	4 s
		Line frequency	55
		Isolation Resistance monitoring	Off
		Sensor Break (Off/Downscale/Upscale)	Off
		Sensor Short circuit (Off/Downscale/Upscale)	Off
		Sensor Drift (Off/Downscale/Upscale)	Off

Table 3: The factory settings for C520/C520X / R520/R520X transmitters

5.3 Configuration alternatives

The 520 series transmitters can be configured by means of:

1. The PC based configuration software ConSoft version 2.0.0.8 or higher and the INOR USB Interface version 1.2.04 or higher, via a USB port on the PC (for more information see the user instructions for the ICON Configuration Kit)
2. A hand held communicator (secondary master) such as the field communicators FC 375 / FC 475 (Emerson)
3. EDD enabled device management softwares/systems (primary master) such as:
 - 1) Smart Device Configurator SDC-625
 - 2) PDM - Process Device Manager (Siemens)
 - 3) AMS - Asset Management Solutions (Emerson)
 - 4) FDM - Field Device Manager (Honeywell)
 - 5) DTM/FDT enabled softwares/systems such as PACTware

5.3.1 Configuration of the 520 series transmitters with ConSoft

ConSoft is a PC based graphical user interface for configuration of all INOR transmitters. The PC configuration software ConSoft is used for configuration, display and documentation. The current software versions of ConSoft and the USB Interface are available for downloading on our website www.inor.com.

To upgrade your USB Interface software to the latest version, use the following flow chart.

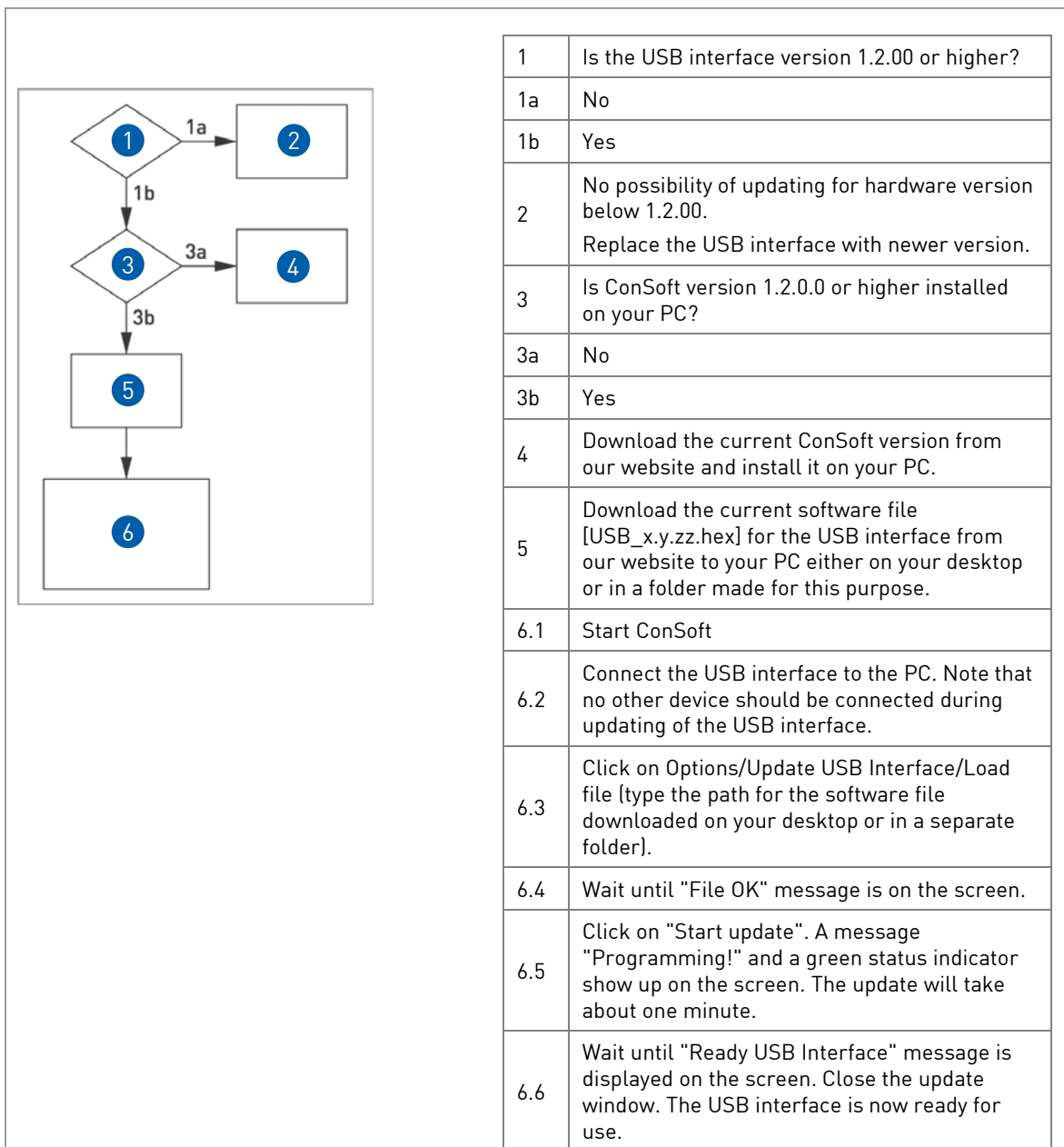

Proper connection of the transmitters with a PC requires an INOR USB Interface (see Figure 17 for connection of the C520/C520X transmitters and figure 18 for connection of the R520/R520X transmitters).



ATTENTION!

Make sure the area is safe before connecting the INOR USB Interface ICON to the transmitter.

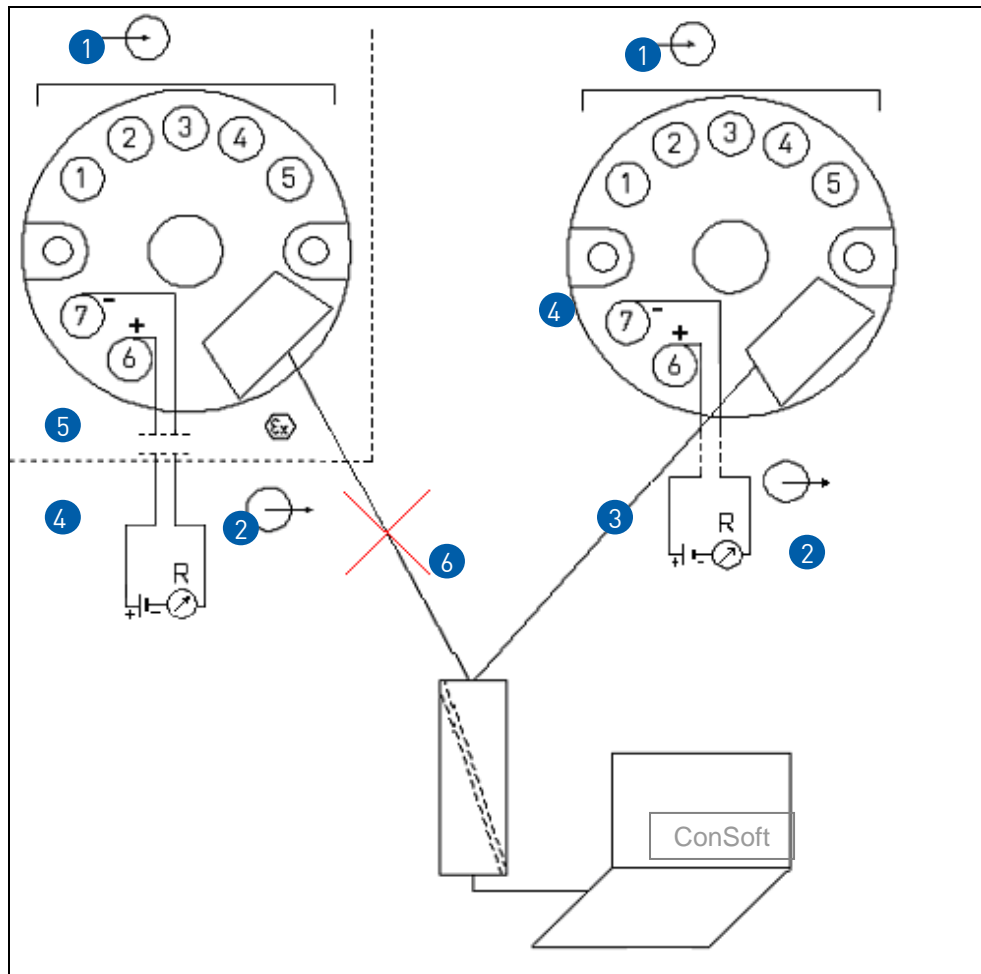

Figure 18: Connection during configuration of C520/C520X

1	Input (intrinsically safe)
2	Output voltage supply (intrinsically safe terminals 6 and 7) and R_{Load} (intrinsically safe)
3	Communication with USB Interface and PC software ConSoft
4	Safe area
5	Classified hazardous area (potentially explosive area e.g. Zone 0, 1 or 2)
6	Connection to USB Interface and PC software ConSoft is not permitted if C520X and/or a connected sensor is placed in the classified hazardous area (potentially explosive area)
7	Connection to the voltage supply during configuration with USB Interface and PC software ConSoft is not needed

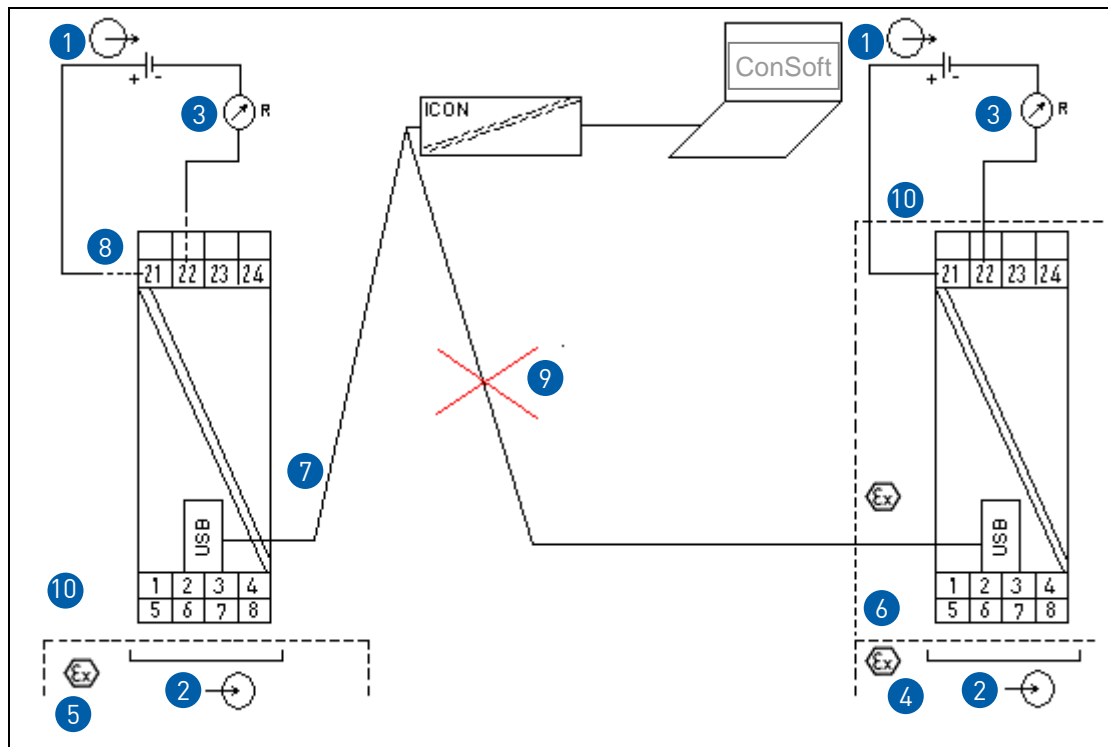

Figure 19: R520X connection to USB Interface and ConSoft during configuration

1	Voltage supply 10...30 VDC (intrinsically safe - terminals 21, 22)
2	Input (intrinsically safe)
3	R_{Load} (intrinsically safe)
4	Classified hazardous area (potentially explosive area e.g. Zone 0)
5	Classified hazardous area (potentially explosive area e.g. Zone 0, 1 or 2)
6	Classified hazardous area (potentially explosive area e.g. Zone 1 or 2)
7	Communication with USB Interface and PC software ConSoft
8	Connection to the voltage supply during configuration with USB Interface and PC software ConSoft is not needed
9	Connection to USB Interface and PC software ConSoft is not permitted if R520X and/or a connected sensor is placed in the classified hazardous area
10	Safe area

5.3.2 Configure the 520 series transmitters with handheld communicators FC 375 / FC 475

The Field communicators FC 375 / FC 475 are handheld communicators from Emerson Process Management for configuring HART and Foundation Fieldbus devices. To be able to configure the transmitters with the FC 375 / FC 475 you need a Device Description (DD) file. The device driver is possible to download from our website www.inor.com.

The transmitter DD has to be installed on the FC 375 / FC 475, otherwise the user will work with the transmitter as generic device losing opportunity to control all features of the transmitter. For installing the DD on the FC 375 / FC 475 the "Easy Upgrade Programming Utility" is needed and the FC 375 / FC 475 must have a system card with "Easy Upgrade" option (see details in the "375 / 475 Field Communicator User's Manual").

The transmitter DD for FC 375 / FC 475 can also be downloaded from our website. For information about installing, follow the instructions in the attached "readme.txt" file.

For proper connection of transmitters with the handheld communicator - see the Figures 7 and 13 for connection of the C520/R520 transmitters and figures 8 and 14 for connection of the C520X/R520X transmitters.

5.3.3 Device management software's

The 520 series transmitters can be configured via PC software's such as AMS Device Manager or Simatic PDM.

The AMS Device Manager is a PC application from Emerson Process Management for configuring and managing HART and Foundation Fieldbus devices. For adaptation to different devices AMS Device Manager uses Device Descriptions (DD).

The C520/C520X / R520/R520X Device Description has to be installed on the AMS System, and a so called "Installation Kit C520/R520 HART AMS" is needed (available as download on the internet).

For installing of the DD with the Installation Kit refer to the "AMS Intelligent Device Manager Books Online" section "Basic AMS Functionality / Device Configurations / Installing Device Types / Procedures / Install device types from media". Please read also the "readme.txt", which is also contained in the Installation Kit.

The "Installation Kit C520/R520 HART AMS" can also be downloaded from our website www.inor.com. For information about installing, follow the instructions in the attached "readme.txt" file.

AMS supports the EDDL Process Variables Root Menu, the Diagnostic Root Menu and the Device Root Menu for online access to the device.

The Simatic PDM is a PC application from Siemens for configuring HART and PROFIBUS devices. For adaptation to different devices Simatic PDM uses Device Descriptions (DD).

The C520/C520X / R520/R520X Device Description has to be installed on the PDM System, and a so called "Device Install C520/R520 HART PDM" is needed (available as download on the internet).

For installing of the DD on PDM refer to the "PDM Manual" section 13:"Integrating Devices". Please read also the "readme.txt", which is also contained in the Device Install. The transmitter DD for PDM can also be downloaded from our website. For information about installing, follow the instructions in the attached "readme.txt" file.

PDM supports the EDDL Process Variables Root Menu, the Diagnostic Root Menu and the Device Root Menu for online access to the device. Furthermore it supports the Offline Root Menu for offline configuration.

5.3.4 Configuration with PACTware

PACTware is a DTM/FDT enabled PC software, which can be downloaded for free on the Internet.

To be able to configure the transmitters via PACTware, download the transmitter DTM (Device Type Manager) file from our website. For information about installing, follow the instructions in the attached "readme.txt" file.

5.4 Current output and HART dynamic/device variables

The C520/C520X / R520/R520X transmitters handle up to eight measurement-related HART device variables. These variables depend on the device's sensor configuration, and each variable is represented by an output signal of 4...20 mA. See Table 4 for more information.

HART Device Variable	Notes
Channel 1	
Channel 2	
Difference 1-2	valid if both channels are equipped with sensors and of the same type
Difference 2-1	valid if both channels are equipped with sensors and of the same type
Minimum	valid if both channels are equipped with sensors and of the same type
Maximum	valid if both channels are equipped with sensors and of the same type
Average	valid if both channels are equipped with sensors and of the same type
Device Temperature	Internal temperature of the transmitter (not available as 4...20 mA signal)

Table 4: The HART dynamic variables for C520/C520X / R520/R520X transmitters



Note!

When the Simulation mode is used (loop check) there is a timer so that after 15 minutes the transmitter returns to normal mode and starts / continues to measure and indicate the actual input value again.

5.5 Diagnostic information according to NAMUR NE 107

Diagnostic information about the connected sensor/sensors and the transmitter is available in the configuration software ConSoft.

The HART diagnostic messages are generated in accordance with NAMUR NE 107.

The following are examples of diagnostic information available both in ConSoft and as HART messages:

- Sensor break (failure / sensor wire break on Ch1 or Ch2)
- Sensor short-circuit (failure / sensor wire short-circuit on Ch1 or Ch2)
- Sensor low isolation (failure / low internal isolation in sensor on Ch1 or Ch2)
- Sensor drift (failure / sensor drift between Ch1 and Ch2)
- Sensor backup, automatic switchover from defective sensor (maintenance required / change the sensor on Ch1 or Ch2)
- Transmitter error (failure/transmitter error, non-correctable in the transmitter)

For complete information about all diagnostic information available from the 520 series transmitters, refer to Table 5, 6, 7 and 8 below.

Messages in AMS, PDM, and FC375 device diagnostic			Actions
Standard	NE 107 Signal [12]	Error message	Error correction
Transmitter	C	Primary variable out of limits	Check the limits for connected sensor. Replace the sensor allocated to the primary variable.
Transmitter	C	Non-primary variable out of limits	Check the limits for connected sensor. Replace the sensor allocated to the non-primary variable.
Transmitter	C	Primary variable analog output saturated	Check the limits for connected sensor. Ambient temperature is higher than stated limits for sensor, which is allocated to the primary variable analog output. Replace the sensor allocated to the primary variable analog output.
Transmitter	I	Primary variable analog output fixed	Transmitter in multi-drop mode or loop test
Transmitter	C	More status variable	Check device specific errors for more information
Transmitter	I	Cold start	Transmitter is in cold start mode
Transmitter	I	Configuration changed	Information for other softwares.
Transmitter	C	Field device malfunction	Make a self-test to find out more. Check even device specific diagnostic. If the error remains replace the device.
Extended device status			
Transmitter	M	Maintenance required	Check Device specific diagnostic for more information about sensors and transmitter.
Transmitter	M	Device variable alert	Check Device specific diagnostic for more information about sensors and transmitter.

Table 5: The HART status messages and diagnostic information for C520/C520X / R520/R520X transmitters

Messages in AMS, PDM, and FC375 device diagnostic		Actions
Device specific	Failure Error message	Error correction
Transmitter	F Sensor break channel 1	Sensor wire broken. Check the sensor and sensor connection on the Channel 1. If error remains replace the sensor connected to Channel 1.
Transmitter	F Sensor break channel 2	Sensor wire broken. Check the sensor and sensor connection on the Channel 2. If error remains replace the sensor connected to channel 2.
Transmitter	F Sensor short circuit channel 1	Sensor wire shorted. Check the sensor and sensor connection on the Channel 1. If error remains replace the sensor connected to Channel 1.
Transmitter	F Sensor short circuit channel 2	Sensor wire shorted. Check the sensor and sensor connection on the Channel 2. If error remains replace the sensor connected to Channel 2.
Transmitter	F Sensor low isolation channel 1	To low isolation in the sensor. Check the sensor by measuring resistance between the wires. If error remains replace the sensor connected to Channel 1.
Transmitter	F Sensor low isolation channel 2	To low isolation in the sensor. Check the sensor by measuring resistance between the wires. If error remains replace the sensor connected to Channel 2.
Transmitter	F Sensor drift	Check the sensors and limits for sensor drift. If error remains replace the faulty sensor.
Transmitter	F System error	Make a self test to find out more, If the error remains replace the device.

Table 6: The HART status messages and diagnostic information for C520/C520X / R520/R520X transmitters

Messages in AMS, PDM, and FC375 device diagnostic		Actions
Device specific	Out of specification Error message	Error correction
Transmitter	S High limit alarm OPM	Check the sensor(s) and sensor connection on both channels. If error remains replace the sensor(s) connected to the transmitter.
Transmitter	S Low limit alarm OPM	Check the sensor(s) and sensor connection on both channels. If error remains replace the sensor(s) connected to the transmitter.
Device specific	Maintenance required Error message	Error correction
Transmitter	M Sensor backup	Transmitter is measuring the working sensor (channel). Replace the faulty sensor.

Table 7: The HART status messages and diagnostic information for C520/C520X / R520/R520X transmitters

Designation	Description
C	Check function
S	Not within specification
M	Maintenance required
F	Failure

Table 8: Explanations acc. to NE107

5.6 Sensor failure monitoring according to NE43

There is possibility of the monitoring of the sensor failure in ConSoft. The difference between the monitoring of the sensor failure in ConSoft and HART is shown in Table 9 below.

ConSoft configuration			HART configuration
Variable name	Possible settings	Factory settings	Comments
Sensor break monitoring	off, downscale (≤ 3.6 mA), upscale (≥ 21 mA) and other value	upscale (≥ 21 mA)	Configuring of the transmitter in ConSoft for other value lower than 21 mA is interpreting as downscale in the transmitter otherwise as upscale during HART configuration.
Sensor short	off, downscale (≤ 3.6 mA), upscale (≥ 21 mA) and other value	upscale (≥ 21 mA)	Configuring of the transmitter in ConSoft for other value lower than 21 mA is interpreting as downscale in the transmitter otherwise as upscale during HART configuration.
Sensor low Isolation	off, downscale (≤ 3.6 mA), upscale (≥ 21 mA) and other value	off	Not permitted for SIL transmitters. Configuring of the transmitter in ConSoft for other value lower than 21 mA is interpreting as downscale in the transmitter otherwise as upscale during HART configuration.

Table 9: The difference between the monitoring of the sensor failure in ConSoft and HART acc. to NE43



NOTE!

Configuring of the sensor failure in ConSoft for other settings that are not according Namur NE43 generates an error message!

5.7 Factory configuration and calibration of the C520/C520X / R520/R520X

The C520/C520X / R520/R520X transmitters are delivered with a factory configuration Pt100 ($\alpha=0.00385$), 4-wire connection, 0...+100°C / +32...+212°F or configured according to customer's requirements (See the Table 3 for detailed information).

Due to the long-term drift of max $\pm 0.01^\circ\text{C}$ or $\pm 0.01\%$ of span per year, a recalibration of the transmitter is normally not needed. Should you for any reason require the recalibration, the transmitter must be returned to the factory.

6.1 C520 specifications

6.1.1 Technical data

Technical data	Designation	Value
Input	Pt100 ($\alpha=0.00385$) IEC 60751	-200...+850°C / -328...+1562°F
	Pt100 ($\alpha=0.003916$) JIS C 1604-81	-200...+850°C / -328...+1562°F
	Pt X ($\alpha=0.00385$) IEC 60751	Corresponding to max. 4000 Ω
Edison curve 7	Ni100 ($\alpha=0.006180$) DIN 43760	-60...+250°C / -76...+482°F
	Ni120 ($\alpha=0.006720$)	-60...+250°C / -76...+482°F
Edison copper winding No.15	Ni1000 ($\alpha=0.006180$) DIN 43760	-50...+180°C / -58...+356°F
	Cu10 ($\alpha=0.004274$)	-50...+200°C / -58...+392°F
	Potentiometer	100...4000 Ω
	Thermocouples	Types: B, C, D, E, J, K, N, R, S, T
	Voltage	-10...1000 mV
	Sensor current	~0.3 mA
	Sensor wire resistance	20 Ω /wire for 2-wire connection 50 Ω /wire for 3/4-wire connection 10000 Ω for thermocouple
	Minimum span	10 Ω / 10°C / 2 mV
Monitoring	Sensor break function	Off, Upscale or downscale ¹⁾
	Sensor short-circuit	Off, Upscale, downscale ¹⁾
	Sensor Drift	Off, Upscale, downscale ¹⁾
Output	Temperature linear for RTD & T/C	4...20 mA, 20...4 mA or customized
	Response time	Single input approx. 300 ms, dual input approx. 600 ms
	Permissible load	635 Ω at 24 VDC incl. 250 Ω loop resistance
Ambient temperature	Operating	-40°C ... +85°C
Humidity		5...95% RH
Vibrations		Acc. to IEC 68-2-6, Test Fc, 10g
Shock		Acc. to IEC 60068-2-31, test Ec
EMC	Standards	EN 61326-1, EN 61326-3-1, NAMUR NE21
EMC Directive	Immunity performance	ESD, Radiated EM-field: Criteria A Surge: ~0.5% of span
Galvanic isolation		1500 VAC, 1 min
Power supply	C520	10...36 VDC, polarity protected
Typical accuracy	For more information see RTD and T/C accuracy table 18	$\pm 0.1^\circ\text{C}$ / $\pm 0.2^\circ\text{F}$
Connection head		DIN B or larger

1) Upscale (≥ 21.0 mA) or downscale (≤ 3.6 mA)

Table 10: C520 specifications

6.1.2 Output load diagram

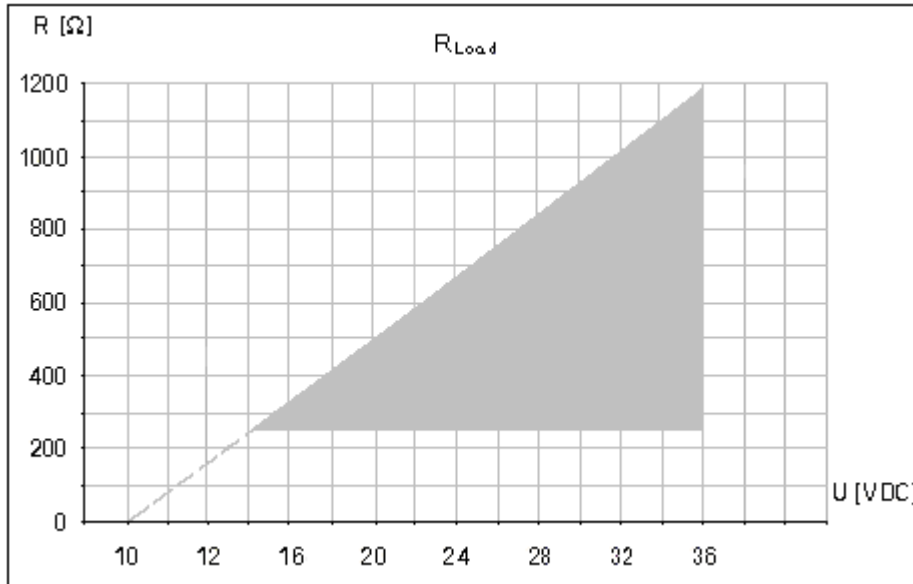

Figure 20: C520 output load diagram

Formula for the maximum permissible output load: C520 permissible $R_{Load} (\Omega) = (U-10)/0.022$

R	Total output load [Ω]
U	Power supply [VDC]

6.1.3 Dimensions

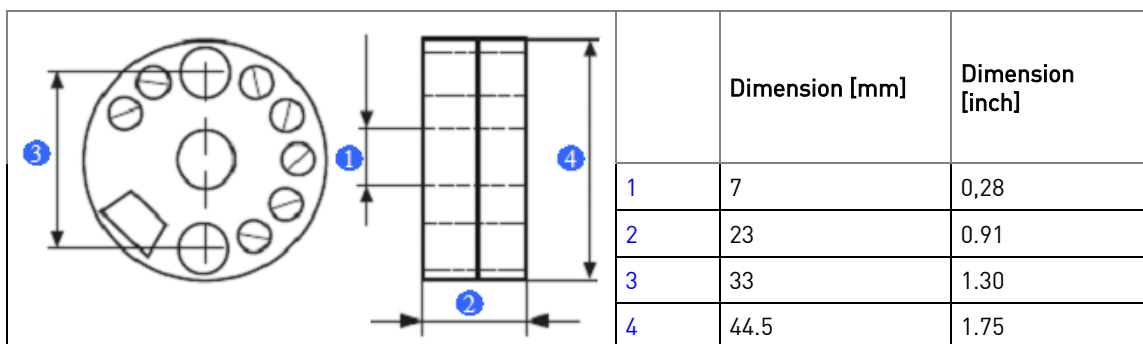

Figure 21: C520 dimensions

6.2 C520X specifications

6.2.1 Technical data

Technical data	Designation	Value
Input	Pt100 ($\alpha=0.00385$) IEC 60751	-200...+850°C / -328...+1562°F
	Pt100 ($\alpha=0.003916$) JIS C 1604-81	-200...+850°C / -328...+1562°F
	Pt X ($\alpha=0.00385$) IEC 60751	Corresponding to max. 4000 Ω
	Ni100 ($\alpha=0.006180$) DIN 43760	-60...+250°C / -76...+482°F
Edison curve 7	Ni120 ($\alpha=0.006720$)	-60...+250°C / -76...+482°F
	Ni1000 ($\alpha=0.006180$) DIN 43760	-50...+180°C / -58...+356°F
Edison copper winding No.15	Cu10 ($\alpha=0.004274$)	-50...+200°C / -58...+392°F
	Potentiometer	100...4000 Ω
	Thermocouples	Types: B, C, D, E, J, K, N, R, S, T
	Voltage	-10...1000 mV
	Sensor current	~0.3 mA
	Sensor wire resistance	20 Ω /wire for 2-wire connection 50 Ω /wire for 3/4-wire connection 10000 Ω for thermocouple
	Minimum span	10 Ω / 10°C / 2 mV
Monitoring	Sensor break function	Off, upscale or downscale ¹⁾
	Sensor short-circuit	Off, upscale, downscale ¹⁾
	Sensor drift	Off, upscale, downscale ¹⁾
Output	Temperature linear for RTD & T/C	4...20 mA, 20...4 mA or customized
	Response time	Single input approx. 300 ms, dual input approx. 600 ms
	Permissible load	635 Ω at 24 VDC incl. 250 Ω loop resistance
Ambient temperature	Operating	See Table 13
Humidity		5...95% RH
Vibrations		Acc. to IEC 68-2-6, Test Fc, 10g
Shock		Acc. to IEC 60068-2-31, test Ec
EMC	Standards	EN 61326-1, EN 61326-3-1, NAMUR NE21
EMC Directive	Immunity performance	ESD, Radiated EM-field: Criteria A Surge: ~0.5% of span
Galvanic isolation		1500 VAC, 1 min
Power supply	C520X	10 ... 30 VDC, polarity protected
Typical accuracy	For more information see RTD and T/C accuracy table 18	$\pm 0.1^\circ\text{C}$ / $\pm 0.2^\circ\text{F}$
Connection head		DIN B or larger

1) Upscale (≥ 21.0 mA) or downscale (≤ 3.6 mA)

Table 11: C520 X specifications

6.2.2 Output load diagram

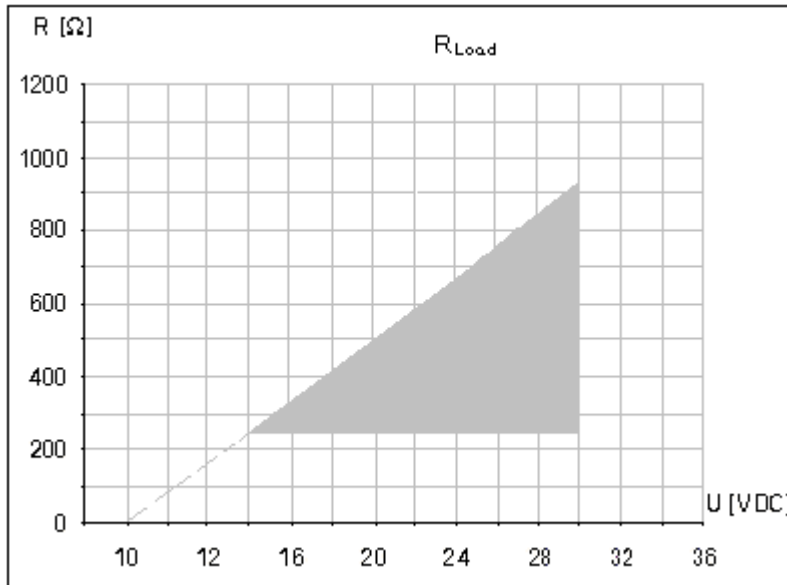

Figure 22: C520X output load diagram

Formula for the maximum permissible output load: C520X permissible $R_{Load} (\Omega) = (U-10)/0.022$

R_{Load}	Total output load [Ω]
U	Power supply [VDC]

6.2.3 Dimensions

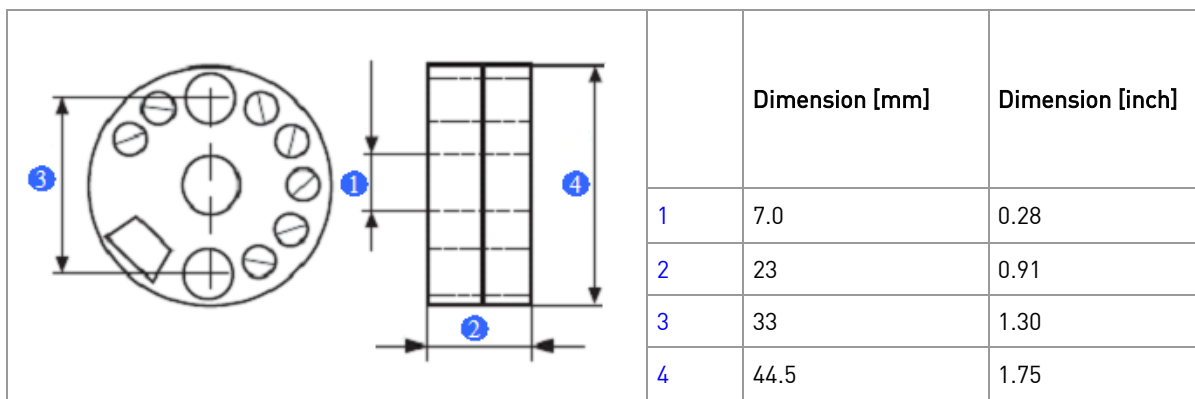

Figure 23: C 520X dimensions

6.2.4 Output and input data



Output terminals 6, 7		Input terminals 1, 2, 3, 4, 5	
$U_i = V_{max}$:	≤ 30 VDC	$U_o = V_{oc}$:	≤ 6.6 VDC
$I_i = I_{max}$:	≤ 100 mA	$I_o = I_{sc}$:	≤ 26.4 mA
$P_i = P_{max}$:	≤ 900 mW	P_o :	≤ 46 mW
L_i :	10 μ H	L_o :	25 mH
C_i :	12.1 nF	C_o :	583 nF

Table 12: Electrical data for outputs-inputs of C520X

6.2.5 Ambient temperature data for areas with potentially explosive atmospheres



Temperature class	Ambient temperature
T6	$-40^{\circ}\text{C} \leq T_a \leq +60^{\circ}\text{C}$ / $40^{\circ}\text{F} \leq T_a \leq +140^{\circ}\text{F}$
T5	$-40^{\circ}\text{C} \leq T_a \leq +75^{\circ}\text{C}$ / $40^{\circ}\text{F} \leq T_a \leq +167^{\circ}\text{F}$
T4	$-40^{\circ}\text{C} \leq T_a \leq +85^{\circ}\text{C}$ / $40^{\circ}\text{F} \leq T_a \leq +185^{\circ}\text{F}$

Table 13: C520X temperature data

6.3 R520 specifications

6.3.1 Technical data

Technical data	Designation	Value
Input	Pt100 ($\alpha=0.00385$) IEC 60751	-200...+850°C / -328...+1562°F
	Pt100 ($\alpha=0.003916$) JIS C 1604-81	-200...+850°C / -328...+1562°F
	Pt X ($\alpha=0.00385$) IEC 60751	Corresponding to max. 4000 Ω
	Ni100 ($\alpha=0.006180$) DIN 43760	-60...+250°C / -76...+482°F
Edison curve No.7	Ni120 ($\alpha=0.006720$)	-60...+250°C / -76...+482 °F
	Ni1000 ($\alpha=0.006180$) DIN 43760	-50...+180°C / -58...+356°F
Edison copper winding No.15	Cu10 ($\alpha=0.004274$)	-50...+200°C / -58...+392°F
	Potentiometer	100...4000 Ω
	Thermocouples	Types: B, C, D, E, J, K, N, R, S, T
	Voltage	-10...1000 mV
	Sensor current	~0.3 mA
	Sensor wire resistance	20 Ω /wire for 2-wire connection 50 Ω /wire for 3/4-wire connection 10000 Ω for thermocouple
	Minimum span	10 Ω
Monitoring	Sensor break function	Off, upscale or downscale ¹⁾
	Sensor short-circuit	Off, upscale, downscale ¹⁾
	Sensor drift	Off, upscale, downscale ¹⁾
Output	Temperature linear for RTD & T/C	4...20 mA, 20...4 mA or customized
	Response time	Single input approx. 300 ms, dual input approx. 600 ms
	Permissible load	635 Ω at 24 VDC incl. 250 Ω loop resistance
Ambient temperature	Operating	-20°C ... +70°C
Humidity		5...95% RH
Vibrations		Acc. to IEC 68-2-6, Test Fc, 10g
Shock		Acc. to IEC 60068-2-31, test Ec
EMC	Standards	EN 61326-1, EN 61326-3-1, NAMUR NE21
EMC Directive	Immunity performance	ESD, Radiated EM-field: Criteria A Surge: ~0.5% of span
Galvanic isolation		1500 VAC, 1 min
Power supply	R520	10...36 VDC, polarity protected
Typical accuracy	For more information see RTD and T/C accuracy table 18	$\pm 0.1^\circ\text{C}$ / $\pm 0.2^\circ\text{F}$
Mounting		35 mm top hat rail acc. to EN 60715

1) Upscale (≥ 21.0 mA) or downscale (≤ 3.6 mA)

Table 14: R520 specifications

6.3.2 Output load diagram

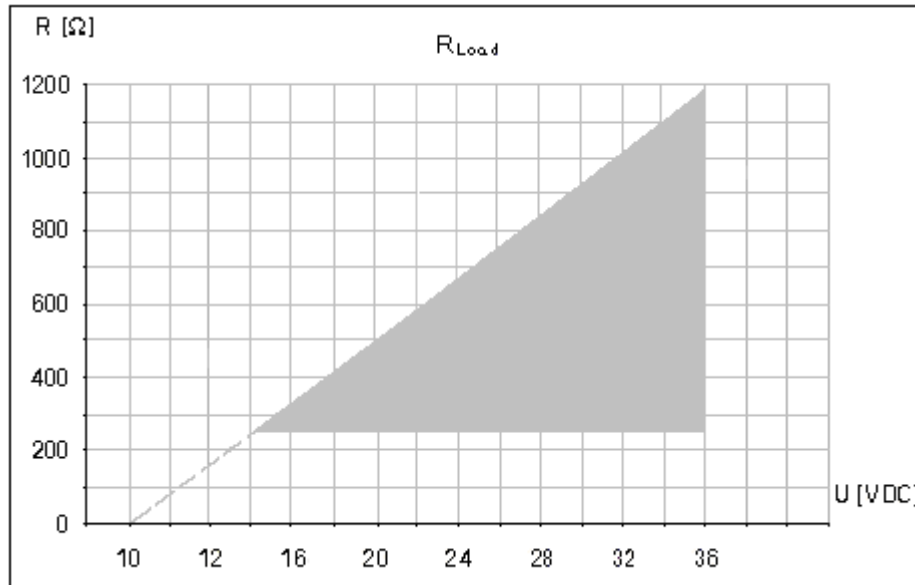

Figure 24: R520 output load diagram

Formula for the maximum permissible output load: R520 permissible $R_{Load} (\Omega) = (U-10)/0.022$

R	Total output load [Ω]
U	Power supply [VDC]

6.3.3 Dimensions

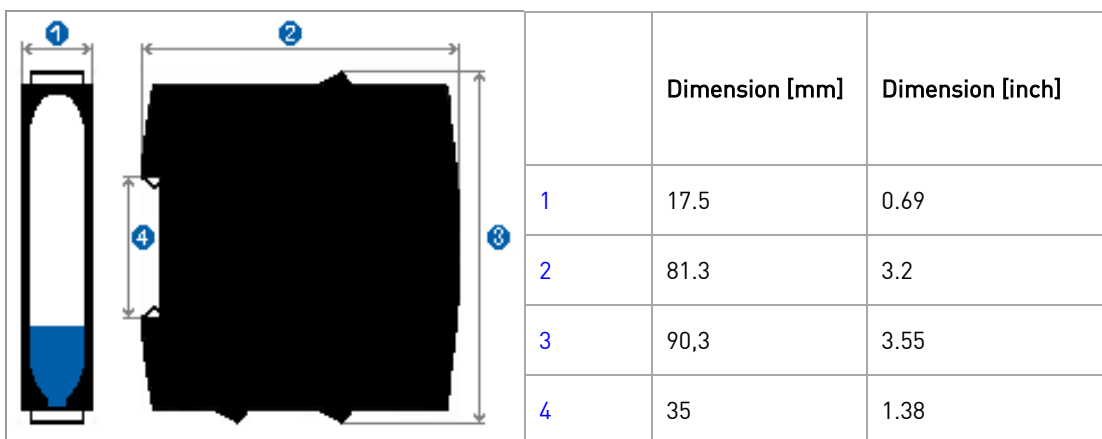

Figure 25: R520 dimensions

6.4 R520X specifications

6.4.1 Technical data

Technical data	Designation	Value
Input	Pt100 ($\alpha=0.00385$) IEC 60751	-200...+850°C / -328...+1562°F
	Pt100 ($\alpha=0.003916$) JIS C 1604-81	-200...+850°C / -328...+1562°F
	Pt X ($\alpha=0.00385$) IEC 60751	Corresponding to max. 4000 Ω
	Ni100 ($\alpha=0.006180$) DIN 43760	-60...+250°C / -76...+482°F
Edison curve 7	Ni120 ($\alpha=0.006720$)	-60...+250°C / -76...+482°F
	Ni1000 ($\alpha=0.006180$) DIN 43760	-50...+180°C / -58...+356°F
Edison copper winding No.15	Cu10 ($\alpha=0.004274$)	-50...+200°C / -58...+392°F
	Potentiometer	100...4000 Ω
	Thermocouples	Types: B, C, D, E, J, K, N, R, S, T
	Voltage	-10...1000 mV
	Sensor current	~0.3 mA
	Sensor wire resistance	20 Ω /wire for 2-wire connection 50 Ω /wire for 3/4-wire connection 10000 Ω for thermocouple
	Minimum span	10 Ω / 10°C / 2 mV
Monitoring	Sensor break function	Off, upscale or downscale ¹⁾
	Sensor short-circuit	Off, upscale, downscale ¹⁾
	Sensor drift	Off, upscale, downscale ¹⁾
Output	Temperature linear for RTD & T/C	4...20 mA, 20...4 mA or customized
	Response time	Single input approx. 300 ms, dual input approx. 600 ms
	Permissible load	635 Ω at 24 VDC incl. 250 Ω loop resistance
Ambient temperature	Operating	See Table 17
Humidity		5...95% RH
Vibrations		Acc. to IEC 68-2-6, Test Fc, 10g
Shock		Acc. to IEC 60068-2-31, test Ec
EMC	Standards	EN 61326-1, EN 61326-3-1, NAMUR NE21
EMC Directive	Immunity performance	ESD, Radiated EM-field: Criteria A Surge: ~0.5% of span
Galvanic isolation		1500 VAC, 1 min
Power supply	R520X	10...30 VDC, polarity protected
Typical accuracy	For more information see RTD and T/C accuracy table 18	$\pm 0.1^\circ\text{C}$ / $\pm 0.2^\circ\text{F}$
Mounting		35 mm top hat rail acc. to EN 60715

1) Upscale (≥ 21.0 mA) or downscale (≤ 3.6 mA)

Table 15: R520X specifications

6.4.2 Output load diagram

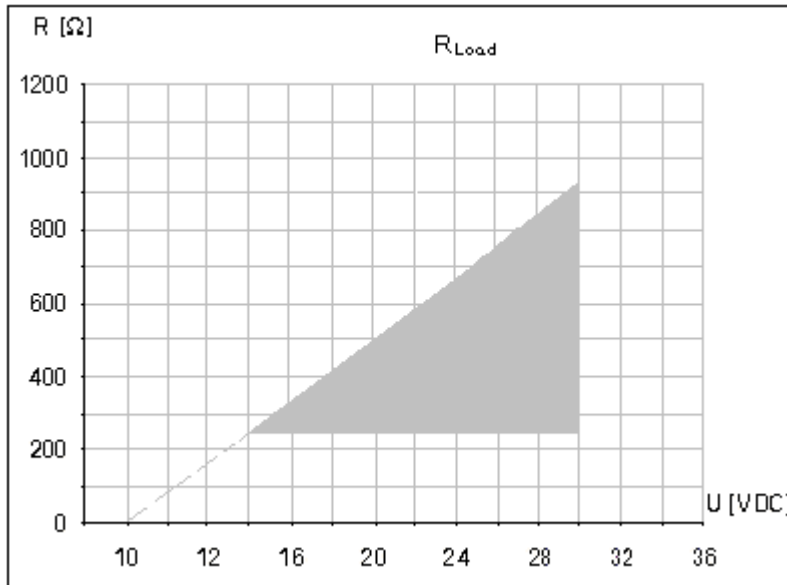

Figure 26: R520X output load diagram

Formula for the maximum permissible output load: R520X permissible $R_{Load} (\Omega) = (U-10)/0.022$

R	Total output load [Ω]
U	Power supply [VDC]

6.4.3 Dimensions

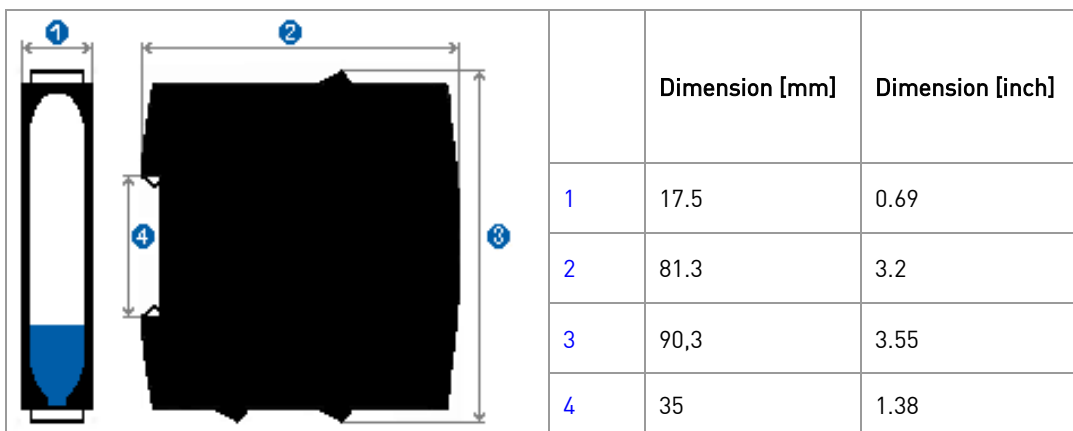

Figure 27: R520X dimensions

6.4.4 Output and input data



Output terminals 21, 22		Input terminals 1 to 8	
$U_i = V_{max}$:	≤ 30 VDC	$U_o = V_{oc}$:	≤ 6.6 VDC
$I_i = I_{max}$:	≤ 100 mA	$I_o = I_{sc}$:	≤ 27.3 mA
$P_i = P_{max}$:	≤ 900 mW	P_o :	≤ 46 mW
L_i :	10 μ H	L_o :	25 mH
C_i :	12.1 nF	C_o :	581 nF

Table 16: Electrical data for outputs-inputs of R520X

6.4.5 Ambient temperature data for areas with potentially explosive atmospheres



Temperature class	Ambient temperature
T6	$-20^{\circ}\text{C} \leq T_a \leq +50^{\circ}\text{C}$ / $-4^{\circ}\text{F} \leq T_a \leq +122^{\circ}\text{F}$
T5	$-20^{\circ}\text{C} \leq T_a \leq +65^{\circ}\text{C}$ / $-4^{\circ}\text{F} \leq T_a \leq +149^{\circ}\text{F}$
T4	$-20^{\circ}\text{C} \leq T_a \leq +70^{\circ}\text{C}$ / $-4^{\circ}\text{F} \leq T_a \leq +158^{\circ}\text{F}$

Table 17: R520X temperature data

6.5 RTD and T/C accuracy table for C520/C520X / R520/R520X transmitters

CJC error not included.
Conformance level 95% (2 σ)

Input type	Temp. range	Min span	Accuracy Max of:	Temp. influence (Dev. fr. ref.temp. 20°C)
RTD Pt100	-200...+850°C	10°C	$\pm 0.10^\circ\text{C}$ or $\pm 0.05\%$ of span	$\pm 0.005\%$ of span per K
RTD Pt1000	-200...+850°C	10°C	$\pm 0.10^\circ\text{C}$ or $\pm 0.05\%$ of span	$\pm 0.005\%$ of span per K
RTD PtX	Corr. to max. 4 k Ω	10°C	$\pm 0.10^\circ\text{C}$ or $\pm 0.05\%$ of span	$\pm 0.005\%$ of span per K
RTD Ni100	-60...+250°C	10°C	$\pm 0.10^\circ\text{C}$ or $\pm 0.05\%$ of span	$\pm 0.005\%$ of span per K
RTD Ni120	-60...+250°C	10°C	$\pm 0.10^\circ\text{C}$ or $\pm 0.05\%$ of span	$\pm 0.005\%$ of span per K
RTD Ni1000	-50...+180°C	10°C	$\pm 0.10^\circ\text{C}$ or $\pm 0.05\%$ of span	$\pm 0.005\%$ of span per K
RTD Cu10	-50...+260°C	83°C	$\pm 1.5^\circ\text{C}$ or $\pm 0.1\%$ of span	$\pm 0.01\%$ of span per K
T/C type B	+400...+1800°C	700°C	$\pm 1^\circ\text{C}$ or $\pm 0.1\%$ of span	$\pm 0.005\%$ of span per K
T/C type C	0...+2315°C	200°C	$\pm 1^\circ\text{C}$ or $\pm 0.1\%$ of span	$\pm 0.005\%$ of span per K
T/C type D	0...+2315°C	200°C	$\pm 1^\circ\text{C}$ or $\pm 0.1\%$ of span	$\pm 0.005\%$ of span per K
T/C type E	-200...+1000°C	50°C	$\pm 0.25^\circ\text{C}$ or $\pm 0.1\%$ of span	$\pm 0.005\%$ of span per K
T/C type J	-200...+1000°C	50°C	$\pm 0.25^\circ\text{C}$ or $\pm 0.1\%$ of span	$\pm 0.005\%$ of span per K
T/C type K	-200...+1350°C	50°C	$\pm 0.25^\circ\text{C}$ or $\pm 0.1\%$ of span	$\pm 0.005\%$ of span per K
T/C type N	-100...+1300°C	100°C	$\pm 0.25^\circ\text{C}$ or $\pm 0.1\%$ of span	$\pm 0.005\%$ of span per K
T/C type N	-250...+100°C	100°C	$\pm 1^\circ\text{C}$	$\pm 0.05\%$ of span per K
T/C type R	-50...+1750°C	300°C	$\pm 1^\circ\text{C}$ or $\pm 0.1\%$ of span	$\pm 0.005\%$ of span per K
T/C type S	-50...+1750°C	300°C	$\pm 1^\circ\text{C}$ or $\pm 0.1\%$ of span	$\pm 0.005\%$ of span per K
T/C type T	-200...+400°C	50°C	$\pm 0.25^\circ\text{C}$ or $\pm 0.1\%$ of span	$\pm 0.005\%$ of span per K

Table 18: RTD and T/C accuracy table for the C520/C520X / R520/R520X transmitters

7.1 Ordering information

Designation	Order No.
C520	70C5200010
C520, SIL 2 compatible	70C5200S10
C520X	70C520X010
C520X, SIL 2 compatible	70C520XS10
R520	70R5200010
R520, SIL 2 compatible	70R5200S10
R520X	70R520X010
R520X, SIL 2 compatible	70R520XS10
ICON, PC configuration kit (USB-connection)	70CFGUS001
Head mounting kit	70ADA00017
DIN-rail adapter	70ADA00015
Configuration ex works	70CAL00001

Table 19: Ordering information

7.2 Disposal

To address proper recovery, recycling, and disposal of customer end-of-life electronic equipment that is consistent with legislative or regulatory requirements, product and packaging materials should be disposed according with the respective waste treatment and disposal regulations of the region or country to which the device is supplied.

This product should not be mixed with other kind of scrap, after usage. It should be handled as an electronic/electric device.



7.3 Maintenance

The C520/C520X / R520/R520X are completely encapsulated; therefore there are no components, which could be repaired or replaced.

7.4 Product liability and guarantee

Use of IPAQ 520 series transmitters for other than the intended purpose or improper installation and operation may lead to loss of the guarantee. The guarantee shall likewise be void if the device is damaged or its function otherwise impaired.

INOR Process AB, or any other affiliated company within the INOR Group (hereinafter jointly referred to as "INOR"), hereby warrants that the Product will be free from defects in materials or workmanship for a period of five (5) years from the date of delivery ("Limited Warranty"). This Limited Warranty is limited to repair or replacement at INOR's option and is effective only for the first end-user of the Product. Upon receipt of a warranty claim, INOR shall respond within a reasonable time period as to its decision concerning:

- 1 Whether INOR acknowledges its responsibility for any asserted defect in materials or workmanship; and, if so,
- 2 the appropriate cause of action to be taken (i.e. whether a defective product should be replaced or repaired by INOR).

This Limited Warranty applies only if the Product:

- 1 is installed according to the instructions furnished by INOR;
- 2 is connected to a proper power supply;
- 3 is not misused or abused; and
- 4 there is no evidence of tampering, mishandling, neglect, accidental damage, modification or repair without the approval of INOR or damage done to the Product by anyone other than INOR.

This Limited Warranty is provided by INOR and contains the only express warranty provided. INOR SPECIFICALLY DISCLAIMS ANY EXPRESS WARRANTY NOT PROVIDED HEREIN AND ANY IMPLIED WARRANTY, GUARANTEE OR REPRESENTATION AS TO SUITABILITY FOR ANY PARTICULAR PURPOSE, PERFORMANCE, QUALITY AND ABSENCE OF ANY HIDDEN DEFECTS, AND ANY REMEDY FOR BREACH OF CONTRACT, WHICH BUT FOR THIS PROVISION, MIGHT ARISE BY IMPLICATION, OPERATION OF LAW, CUSTOM OF TRADE OR COURSE OF DEALING, INCLUDING IMPLIED WARRANTIES OF MERCHANTABILITY AND FITNESS FOR A PARTICULAR PURPOSE. EXCEPT AS PROVIDED HEREIN, INOR FURTHER DISCLAIMS ANY RESPONSIBILITY FOR LOSSES, EXPENSES, INCONVENIENCES, SPECIAL, DIRECT, SECONDARY OR CONSEQUENTIAL DAMAGES ARISING FROM OWNERSHIP OR USE OF THE PRODUCT.

Products that are covered by the Limited Warranty will either be repaired or replaced at the option of INOR. Customer pays freight to INOR, and INOR will pay the return freight by post or other "normal" way of transport. If any other type of return freight is requested, customer pays the whole return cost.

7.5 Support

Inor Process AB PO Box 9125 SE-200 39 MALMÖ Sweden Phone: +46-(0)40-31 25 60 Fax: +46-(0)40-31 25 70 E-mail: support@inor.se	Inor Transmitter Oy Unikkotie 13 FI-01300 VANTAA Finland Phone: +358-(0)10-4217900 Fax: +358-(0)10-4217901 E-mail: myynti@inor.fi	Inor Transmitter GmbH Am See 24 D-47279 Duisburg Germany Phone: +49-(0)203 7382 762 0 Fax: +49-(0)203 7382 762 2 E-mail: info@inor-gmbh.de
---	---	---



INOR

www.inor.com, www.inor.se