



MinIPAQ R230

Universal Programmable 2-wire transmitter



MinIPAQ R230 is a universal, programmable non-isolated, temperature transmitter with additional voltage and resistance input. Its robust design and high quality gives good performance and accuracy also under harsh conditions.

MinIPAQ R230 supports communication via NFC (Near-field communication) and Bluetooth® which makes it possible to configure and monitor the transmitter remotely.

- Accepts RTD, T/C, mV and Ω
- Sensor error and system (sensor/transmitter) error correction for highest total accuracy
- Configuration via PC, NFC or Bluetooth® without external power
- Runtime counter - hour counter for elapsed operational time
- Rugged design tested for 5 g vibrations
- High security - Password protection and date of changes logged

Specifications:

Input RTD	2-, 3-, 4-wire connection
Pt100 ($\alpha = 0.00385$) ¹⁾	-200 to +850 °C / -328 to +1562 °F
PtX 10 $\leq X \leq 1000$ ($\alpha = 0.00385$) ¹⁾	-200 to +850 °C / -328 to +1562 °F
Ni100 ²⁾ , Ni120 ³⁾	-60 to +250 °C / -76 to +482 °F
Ni1000 ²⁾	-50 to +180 °C / -58 to +356 °F
Input Resistance	0 to 4000 Ω
Input Thermocouples	Types B, C, D, E, J, K, N, R, S, T
Input mV	-10 to +1000 mV
Sensor failure	Upscale (≥ 21.0 mA) or downscale (≤ 3.6 mA) action
Adjustments - Zero	Any value within range limits
Adjustments - Minimum spans	
RTD	10 °C / 18 °F
T/C, mV	2 mV
Output	4-20 mA, temperature linear
Operating temperature	-40 to +85 °C / -40 to +185 °F
Galvanic isolation	No
Power supply	8.0...36.0 VDC
Typical accurac , (RTD)	Max. of ± 0.15 K or ± 0.15 % of span
Mounting	35 mm DIN rail acc. to EN 60715

¹⁾ IEC 60751, ²⁾ DIN 43760, ³⁾ Edison Curve No. 7

Input connections

See data sheet for more alternatives

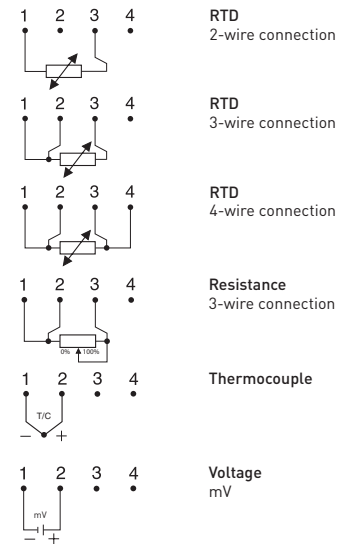

Output connections

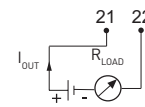

Output load diagram

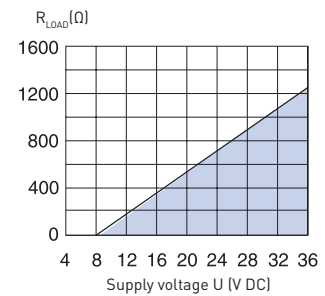

$$R_{LOAD} = (U - 8) / 0.022$$

Dimensions

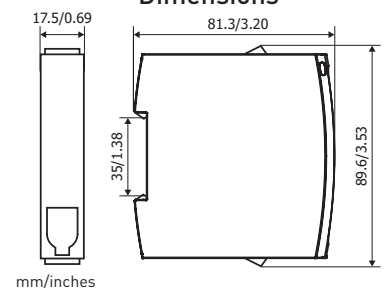

Ordering information

MinIPAQ R230	70R2300011
PC configuration kit (USB-conn.)	70CFGUSX01
ICON-BT, Bluetooth® configuration kit	70CFGBT001