



## OPTITEMP TRA/TCA Technical Datasheet

Industrial thermometers with replaceable measuring inserts.

- Different process connections
- Straight, reduced and tapered thermowell tips
- Replaceable, spring-loaded measuring insert



<b>1</b>	<b>Product features</b>	<b>4</b>
1.1	Thermometer assemblies for industrial applications	4
1.2	Options and variants	6
1.3	Measuring principle	10
1.3.1	Resistance thermometer	10
1.3.2	Thermocouples	11
<b>2</b>	<b>Technical data</b>	<b>12</b>
2.1	Technical data tables	12
2.2	Dimensions	16
2.2.1	Connection heads	16
2.2.2	Thermowells and measuring inserts	17
2.2.3	Threaded sleeve	22
2.2.4	Thermowells: Diameter, wall thickness, tips	23
2.2.5	Flanges	24
2.3	Measuring accuracy	25
2.4	Process connections	26
2.5	Measuring range and permitted load	27
2.6	Permissible temperatures	30
2.6.1	Connection head	30
2.6.2	Unloaded thermowell and immersion tubes	30
2.7	Sensor response times	31
2.8	Limiting values for clamping ring connection and compression type fittings	31
<b>3</b>	<b>Installation</b>	<b>32</b>
3.1	Intended use	32
3.2	General notes on installation	32
3.3	Storage	32
3.4	Transport	32
3.5	Proper installation	33
3.5.1	Possible installations	33
3.5.2	Other installation requirements	34
3.6	Load limits	35
3.6.1	Typical load types	35
3.6.2	Vibration load	38
3.6.3	Temperature load	38
3.7	Installation notes on the individual device classes	40
3.7.1	Insertion-type thermometer	40
3.7.2	Threaded thermometer	41
3.7.3	Flange thermometer	42
3.7.4	Insertion-type thermometer without thermowell	43

4 Electrical connections	44
4.1 Safety instructions.....	44
4.2 Grounding .....	44
4.3 Protection category .....	44
4.4 Power supply .....	44
5 Order information	45
5.1 Type code VTS1 .....	45
5.2 Type code VTS4.....	53

## 1.1 Thermometer assemblies for industrial applications

The thermometer assemblies in the **OPTITEMP TRA/TCA** series can be used in a wide variety of areas in industrial measurement technology. All variants have the option of replacing the measuring inserts. The main feature differentiating all thermometer assemblies is its process connection:

- **Insertion-type thermometer:** available with or without thermowell, usually attached with a compression fitting; an all-purpose device since the decision as to the required insertion depth is only necessary immediately prior to installation.
- **Threaded thermometer:** without the neck tube, these thermometers are predominantly used in the lower temperature range (up to +150°C / +302°F); when they feature a neck tube, spatially separating the process connection from the connection head, the connection head cannot heat up as much; this is particularly important when there is a temperature transmitter in the connection head.
- **Flange thermometer:** their main field of application is in tanks or pipelines and a weld neck flange is used to connect them; the particular advantage to this type of thermometer is that they can be coated (e.g. with PTFE), making them resistant to aggressive media.



- ① TRA/TCA-P10: insertion-type thermometer with straight tip
- ② TRA/TCA-S21: threaded thermometer without neck tube with reduced tip
- ③ TRA/TCA-F42: flange thermometer with tapered tip

All thermometer assemblies feature a sturdy design, careful workmanship and dimensional accuracy. Certified materials, built-in quality control checks and consistent final inspections guarantee the consistently high quality of our products. For more information on the available connection heads, please refer to the OPTITEMP TRA/TCA manual.

## Highlights

- Replaceable measuring inserts with terminal block, flying wires or head-mounted transmitter
- Intrinsically safe versions for use in hazardous areas
- Quick response versions (thermowell tip with  $\varnothing$  6 mm / 0.24")
- Spring-loaded measuring inserts ensure secure contact with the bottom of the thermowell and thus good heat transfer
- Large measurement range: -200...+600°C / -328...+1112°F when using measuring inserts with resistance sensor, -40...+1000°C / -40...+1832°F with thermocouple
- Optional Ex approvals: all thermometer assemblies featuring a measuring insert with a diameter of 6 mm / 0.24" are available in an intrinsically safe version.
- Compliance to NAMUR

## Industries:

- Chemical and petrochemical
- Oil and gas
- Power generation
- Machine building
- Pharmaceuticals and Food & Beverage
- Water and wastewater
- Iron and Steel
- Pulp and paper

## Applications

The thermometer assemblies with various process connections can be used in almost any industrial field:

- Insertion-type thermometers are particularly well suited to simple measuring tasks under ambient pressure and for low flow velocities in mechanical and plant engineering.
- Threaded thermometers without thermowell are predominantly used to measure the temperature of solids or monitor the temperature in gear units, bearings or machine components.
- Threaded thermometers are recommended for general temperature measurement in pipelines and tanks for all industrial areas, even with higher pressures and flow velocities.
- Flange thermometers are designed for low and average operating pressures predetermined by the size of the flange; they are suitable for use in pipelines, tanks and reactors and are primarily used in the chemical industry

## 1.2 Options and variants

### Thermometer assembly and process connection design

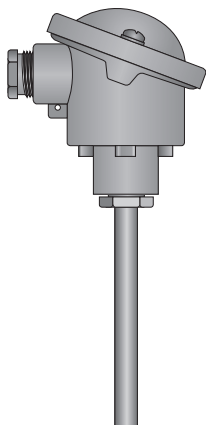

#### Insertion-type thermometer with and without thermowell

- Material 1.4571 / 316 Ti: Ø 9 / 11 / 12 mm or Ø 0.35 / 0.43 / 0.47"
- Material 1.4404 / 316 L: Ø 10 / 12 mm or Ø 0.39 / 0.47", Ø 6 mm or Ø 0.24" only for insertion-type thermometer without thermowell
- ATEX - II 1G Ex ia IIC T6 and II 1D Ex iaD 20 IP65/140°C (284°F) for insertion-type thermometers with thermowell or II 1D Ex iaD 20 IP65/175°C (347°F) for insertion-type thermometers without thermowell

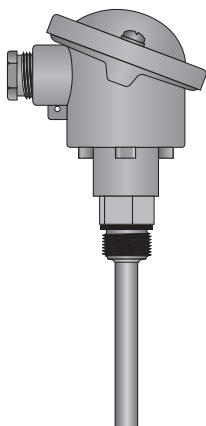

#### Threaded thermometer without neck tube

Process connections:

- G $\frac{1}{2}$ , G $\frac{3}{4}$ , G1
- $\frac{1}{2}$ -14 NPT,  $\frac{3}{4}$ -14NPT

Materials and diameters:

- Material 1.4571 / 316 Ti: Ø 9 / 11 / 12 mm or Ø 0.35 / 0.43 / 0.47"
- Material 1.4404 / 316 L: Ø 10 / 12 mm or Ø 0.39 / 0.47"
- ATEX - II 1/2G Ex ia IIC T6 and II 1D Ex iaD 20 IP65/140°C (284°F)

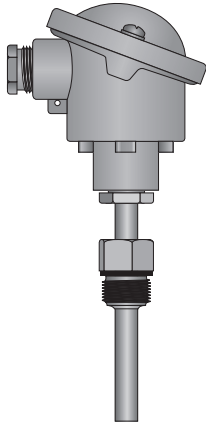

#### Threaded thermometer with neck tube

Process connections:

- G $\frac{1}{2}$ , G $\frac{3}{4}$ , G1
- $\frac{1}{2}$ -14 NPT,  $\frac{3}{4}$ -14NPT

Materials and diameters:

- Material 1.4571 / 316 Ti:  $\varnothing$  9 / 11 / 12 mm or  $\varnothing$  0.35 / 0.43 / 0.47"
- Material 1.4404 / 316 L:  $\varnothing$  10 / 12 mm or  $\varnothing$  0.39 / 0.47"
- ATEX - II 1/2G Ex ia IIC T6 and II 1D Ex iaD 20 IP65/140°C (284°F)

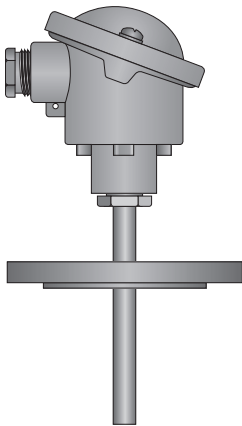

#### Flange thermometer with neck tube

Process connections:

- PN40: DN25 and DN50 acc. to DIN, B1
- 150 and 300 lb: 1" and 1 $\frac{1}{2}$ " acc. to ANSI, RF

Materials and diameters:

- Material 1.4571 / 316 Ti:  $\varnothing$  9 / 11 / 12 mm or  $\varnothing$  0.35 / 0.43 / 0.47"
- Material 1.4404 / 316 L:  $\varnothing$  10 / 12 mm or  $\varnothing$  0.39 / 0.47"
- ATEX - II 1/2G Ex ia IIC T6 and II 1D Ex iaD 20 IP65/140°C (284°F)

## Thermowell tip designs

**Straight thermowell tip**

Materials and diameters:

- Material 1.4571 / 316 Ti:  $\varnothing$  9 / 11 / 12 mm or  $\varnothing$  0.35 / 0.43 / 0.47"
- Material 1.4404 / 316 L:  $\varnothing$  10 / 12 mm or  $\varnothing$  0.39 / 0.47"

Special features:

- For variants TRA/TCA-P10/-S11/-S12/-F13
- Only for measuring inserts with  $\varnothing$  6 mm or  $\varnothing$  0.24"
- High load capacity
- With ATEX approval

**Tapered thermowell tip**

Materials and diameters:

- Material 1.4571 / 316 Ti:  $\varnothing$  12 mm or  $\varnothing$  0.47"
- Material 1.4404 / 316 L:  $\varnothing$  12 mm or  $\varnothing$  0.47"

Special features:

- For variants TRA/TCA-P40/-S41/-F42
- Only for measuring inserts with  $\varnothing$  6 mm or  $\varnothing$  0.24"
- Quick response and high load capacity
- With ATEX approval

**Reduced thermowell tip**

- For variants TRA/TCA-P21/-S21/-S22/-F23
- Material 1.4571 / 316 Ti:  $\varnothing$  11 / 12 mm or  $\varnothing$  0.43 / 0.47"
- Only for measuring inserts with  $\varnothing$  3 mm or  $\varnothing$  0.24"
- Quick response with average load capacity

## Measuring insert designs

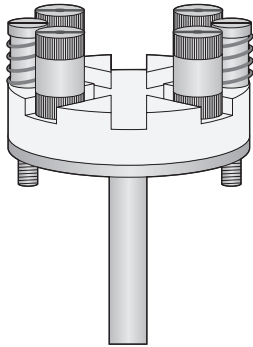

- Fully sealed solder joints
- Pt100 connection in 2, 3 and 4-wire connection
- Available with 2, 3, 4, 6 or 8 connection terminals
- Sheath diameter: 3 + 0 - 0.1 mm
- Sheath diameter: 6 + 0 - 0.1 mm
- Washer disc with 2 screws, 2 springs and 2 retaining rings

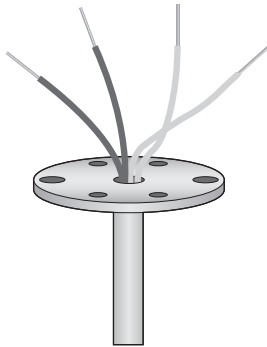

Excepting the following points, the features correspond to those of the version with ceramic terminals:

- Colour-coded, Teflon-insulated lead wires
- Lead wires measuring 50 mm / 1.97" in length for the first measuring point
- Lead wires measuring 100 mm / 3.94" in length for the second measuring point

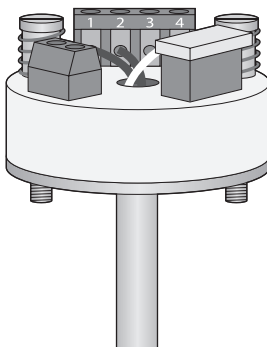

The features correspond to those of the version with flying wire ends. A mounted temperature transmitter is also included in delivery:

## 1.3 Measuring principle

All of the thermometers described here belong to the class known as "contact thermometers". Unlike "radiation thermometers", these thermometers come into direct contact with the medium whose temperature they are to measure.

The type of measuring principle depends on the measuring insert sensor that you combine with the transmitter. Two different sensor types are available. Their respective measuring principles are described in the following subsections.

### 1.3.1 Resistance thermometer

The measuring insert with a resistance thermometer features a temperature-sensitive sensor made from a platinum RTD, whose value at 0°C / +32°F is 100 Ω. That is where the name "Pt100" comes from.

It is generally valid that the electric resistance of metals increases according to a mathematical function as the temperature rises. This effect is taken advantage of by resistance thermometers to measure temperature. The "Pt100" thermometer features a measuring resistance with defined characteristics, standardised in IEC 60751. The same is true for the tolerances. The average temperature coefficient of a Pt100 is  $3.85 \times 10^{-3} \text{ K}^{-1}$  in the range from 0...+100°C / +32...+212°F.

During operation, a constant current  $I (\leq 1 \text{ mA})$  flows through the Pt100 RTD, which brings about a voltage drop  $U$ . The resistance  $R$  is calculated using Ohm's Law ( $R=U/I$ ). As the voltage drop  $U$  at 0°C / +32°F is 100 mV, the resulting resistance of the Pt100 thermometer is 100 Ω (100 mV / 1 mA = 100 Ω).

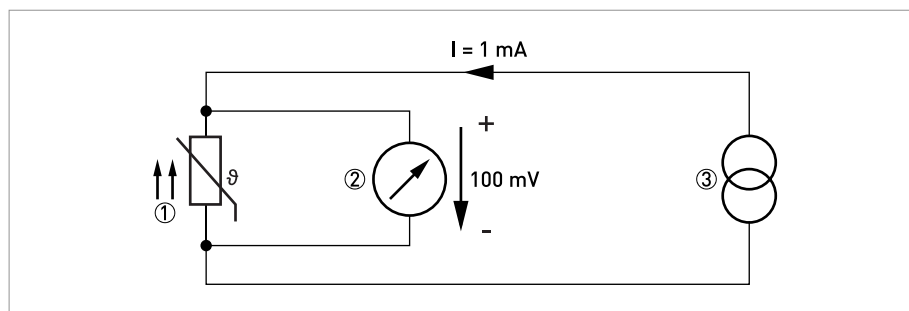

Figure 1-1: Pt100 resistance thermometer in 4-wire connection at 0°C / +32°F, schematic.

- ① Pt100 RTD
- ② Voltage meter
- ③ Current source

### 1.3.2 Thermocouples

The thermocouple features two electric conductors made from different metals, connected at one end. Each free end is connected to a compensation cable which is then connected to a millivolt meter. This circuitry forms a "thermal circuit". The point at which the two electric conductors connect is called the measuring point and the point at which the compensation cables connect to the conductors of the millivolt meter is called the cold junction.

If the measuring point of this thermal circuit is heated up, a small electrical voltage (thermal voltage) can be measured. If, however, the measuring point and the cold junction are at the same temperature, no thermoelectric voltage is generated. The degree of thermoelectric voltage, also known as electromotive force (EMF), depends on the thermocouple material and the extent of the temperature difference between the measuring point and the cold junction. It can be measured using the millivolt meter with no auxiliary power.

Simply put, the thermocouple behaves like a battery, the voltage of which also increases as the temperature rises.

*The characteristic curves and tolerances of commercially available thermocouples are standardised in IEC 60584.*

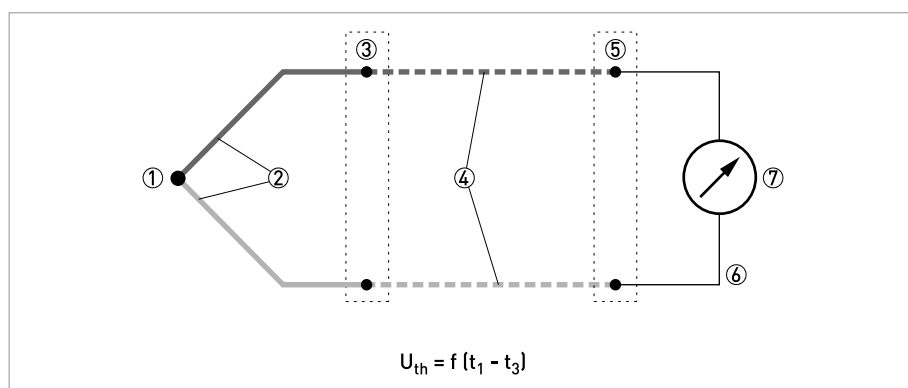

Figure 1-2: Thermocouple measuring circuit, schematic.

- ① Measuring point  $t_1$  (hot junction)
- ② Thermocouple
- ③ Transition junction  $t_2$
- ④ Compensation cable / extension cable
- ⑤ Reference junction  $t_3$  (cold junction)
- ⑥ Copper conductor
- ⑦ Voltage meter  $U_{th}$

## 2.1 Technical data tables

- *The following data is provided for general applications. If you require data that is more relevant to your specific application, please contact us or your local representative.*
- *Additional information (certificates, special tools, software,...) and complete product documentation can be downloaded free of charge from the website (Download Center).*

### Measuring system

Application range	Measuring the temperature of gases, liquids, vapours and solid bodies in industrial processes. The devices are particularly suited to liquids with low viscosity, water and chemicals with low corrosiveness as well as saturated steam and superheated steam.
Measuring principle	Contact thermometer
Measured value	Temperature

### Design

Modular design	Industrial thermometers consist of several components which, together, form a thermometer assembly: <ul style="list-style-type: none"> <li>• Measuring insert with temperature sensor</li> <li>• Transmitter (either inside on the measuring insert or outside)</li> <li>• Connection head</li> <li>• Thermowell with or without neck tube (no thermowell with version TRA/TCA-P14)</li> </ul>
Signal converter	Analogue or digital temperature transmitter in the TT family as head-mount or rail-mount transmitter.
Sensor	Pt100 RTD as thin layer variant (TF) or as wire wound variant (WW) with a characteristic according to DIN EN 60751. Type "J" or "K" thermocouple with a characteristic according to DIN EN 60584.
Measuring range	See "Operating conditions".

<b>Display and user interface</b>	
Display	Only in connection head "BUZ-HW": 4...20 mA, non-illuminated, LCD, loop display.
Operation	Only in connection head "BUZ-HW": interior keys.
Display functions	Temperature, either as output signal (HART® penetrable) in mA or scaled to °C/°F.

### Measuring accuracy

Reference conditions	Ambient temperature: +23°C / +73.4°F (fluctuations due to air pressure and density have no impact on measuring accuracy).
Maximum measuring error	<p>More detailed information in the subsection "Measurement Error" (also in the "Technical Data" section). The maximum measurement error also depends on the type of sensor:</p> <ul style="list-style-type: none"> <li>• Measuring insert with Pt100 RTD: measurement error in accordance with tolerance classes A, B, 1/3 B and 1/10 B according to DIN EN 60751.</li> <li>• Thermocouple: measurement error in accordance with tolerance class 1 acc. to DIN EN 60584.</li> </ul>

### Operating conditions

Load limits	The load limits depend on several factors (e.g. dimensions, design and material of thermowell). Other information can be found in the "Installation" section or in separate subsections of section "Technical data".
	Thermometer without thermowell: 0.8...1.2 bara / 11.6...17.4 psia.
<b>Temperature</b>	
Process temperature	Maximum -200...+600°C / -328...+1112°F, depending on measuring insert, design and material.
Ambient temperature	Maximum -40...+100°C / -40...+212°F, depending on connection head and measuring insert.
Storage temperature	-40...+70°C / -40...+158°F at 40...60% relative humidity.
<b>Other conditions</b>	
Protection categories	Depending on the connection head: IP54 (BKK), IP65 (BA, BUZ-T/S/H/HW, BVA), IP67 (BGK), IP68 (AXD).

**Installation conditions**

Insertion angle	90° to the flow, directly against or diagonally against the flow.
Insertion length	10...15 x thermowell diameter, minimum 100 mm / 3.94" (shorter insertion lengths possible but they impair measuring accuracy).
Pipes with $\varnothing \leq 300$ mm / 11.8"	The thermowell tip should project past the middle of the pipe.
Pipes with $\varnothing > 300$ mm / 11.8"	The thermowell tip may only project beyond the middle of the pipe when the mechanical load permits and the thermowell is not excited in its resonance; when in doubt, check the individual case again.
Bending radius	The immersion tubes on the measuring inserts can be bent but the smallest bending radius must be at least three times the diameter of the immersion tube. Note: Do not bend the bottom 50 mm / 2"!

**Materials**

Thermowells (including process connection)	The materials of the thermowells, neck tubes, flanges and threads as process connections are always identical:
	<b>Standard:</b>
	1.4571 / AISI 316 Ti (X6CrNiMoTi 17-12-2)
	<b>Optional:</b>
	1.4841 / AISI 314/310 (X15CrNiSi 25-21) or 1.4404 / AISI 316 L (X2CrNiMo 17-12-2)
Clamping ring connection	1.4571 / AISI 316 Ti (X6CrNiMoTi 17-12-2), metal or PTFE clamping ring
Connection heads	Aluminium (powder coated), plastic or stainless steel
Measuring inserts	With Pt100 RTD: 1.4404 / AISI 316 L (X2CrNiMo 17-12-2)
	With thermocouple: Inconel 600®

**Process connections and connection head thread**

Insertion-type thermometer (including version without thermowell)	Insert, weld in (not possible with TRA/TCA-P14) or attach using clamping ring connection (thread: G½, G¾, G1, ½-14 NPT or ¾-14 NPT).
Threaded thermometer (with and without neck tube)	Thread acc. to DIN/ISO 228 (G½, G¾ or G1) or ANSI/ASME B1.20.1 (½-14 NPT and ¾-14 NPT), other sizes on request.
	Attachment using welding sleeves. Starting at a wall thickness of 20 mm / 0.8", it is possible to screw in directly with thread in the pipe
Flange thermometer	Acc. to DIN EN 1092-1: B1-DN25 / PN40, B1-DN50 / PN40, other sizes on request.
	Acc. to ASME B16.5: RF 1" / 150 lb, RF 1" / 300 lb, RF 1½" / 150 lb, RF 1½" / 300 lb, other sizes on request.
	Surface roughness of the flange raised face is $R_z = 12.5...50$ µm (DIN EN flanges), $R_a = 3.2...6.3$ µm (ASME flanges).
Connection head	M24 x 1.5 thread to connect to thermowell or neck tube.

**Electrical connections**

Power supply	Only necessary when using a temperature transmitter and depends on transmitter type, typically 24 VDC.
Power consumption	Only when using a temperature transmitter, typically 550 mW.
Cable entry (connection head)	M20 x 1.5
<b>Current output</b>	
Output range	Exists only when using a temperature transmitter and depends on transmitter type, typically 4...20 mA, HART <sup>®</sup> , Profibus-PA.
Error signal	According to NAMUR NE 43, selectable: upper value $\geq 21.0$ mA, lower value $\leq 3.6$ mA.
Load	Relevant only when using a temperature transmitter and then dependent on transmitter type (typically 250 $\Omega$ ).
<b>Other electrical characteristics</b>	
Galvanic isolation	Relevant only when using a temperature transmitter (see transmitter handbook).
Time constant	More detailed information can be found in the subsection "Response times" of the section "Technical data".

**Approvals and certificates**

Electromagnetic compatibility	See handbook for temperature transmitter used.
ATEX	Ex-i available for all thermometers with a measuring insert featuring a diameter of 6 mm / 0.24" and the following sensor: 1 x Pt100, class A, wire-wound RTD.
Functional safety	SIL2 with temperature transmitter TT51 C/R

## 2.2 Dimensions

### 2.2.1 Connection heads

**BA (aluminium, IP65)**

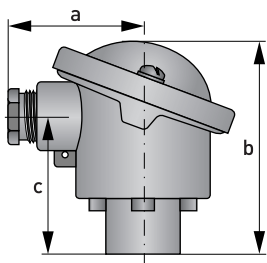

a: 47 mm / 1.85"  
b: 75 mm / 2.95"  
c: 50 mm / 1.97"

**BUZ-T (aluminium, Ex, IP65)**

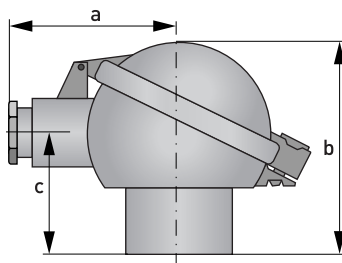

a: 64 mm / 2.52"  
b: 83 mm / 3.26"  
c: 41.5 mm / 1.63"

**BUZ-S (aluminium, IP65)**

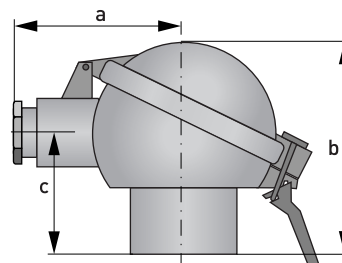

a: 64 mm / 2.52"  
b: 83 mm / 3.26"  
c: 41.5 mm / 1.63"

**BUZ-H (aluminium, Ex, IP65)**

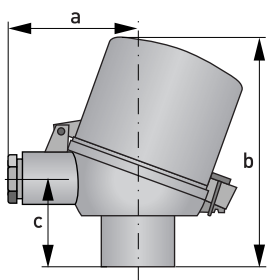

a: 63 mm / 2.48"  
b: 114 mm / 4.45"  
c: 41.5 mm / 1.63"

**BUZ-HW (aluminium, IP65)**

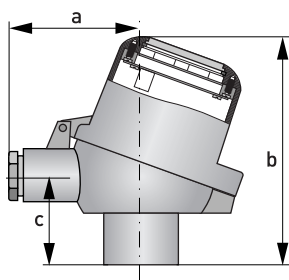

a: 63 mm / 2.48"  
b: 114 mm / 4.45"  
c: 41.5 mm / 1.63"

**BGK (aluminium, IP67)**

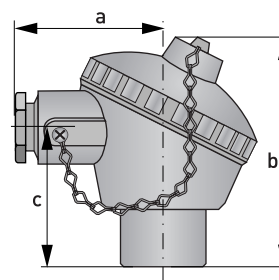

a: 60 mm / 2.36"  
b: 95 mm / 3.74"  
c: 57 mm / 2.24"

**BBK (PA, IP54)**

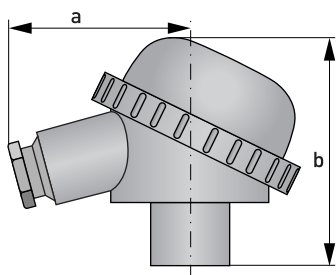

a: 70 mm / 2.76"  
b: 72 mm / 2.83"

**BVA (VA, IP65)**

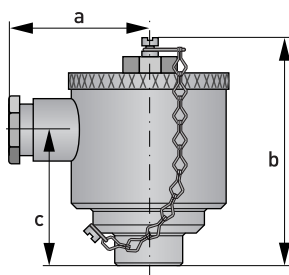

a: 49 mm / 1.93"  
b: 85 mm / 3.35"  
c: 50 mm / 1.97"

**AXD (aluminium, Ex, IP68)**

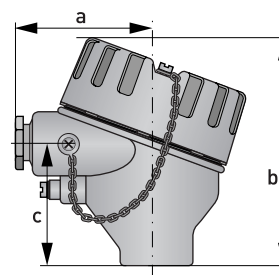

a: 64 mm / 2.52"  
b: 115 mm / 4.53"  
c: 64 mm / 2.52"

## 2.2.2 Thermowells and measuring inserts

The dimensions for the thermowells and measuring inserts given in this subsection are standard measurements. Upon request the manufacturer can supply devices with other dimensions. The diameter the industrial thermometer's measuring insert must have depends on the existence of a thermowell and on the thermowell tip:

- Thermowell with reduced tip: measuring insert with  $\varnothing$  3 mm / 0.12"
- Straight thermowell and thermowell with tapered tip:  $\varnothing$  6 mm / 0.24"
- Version without thermowell:  $\varnothing$  6 mm / 0.24"

### Insertion-type thermometer

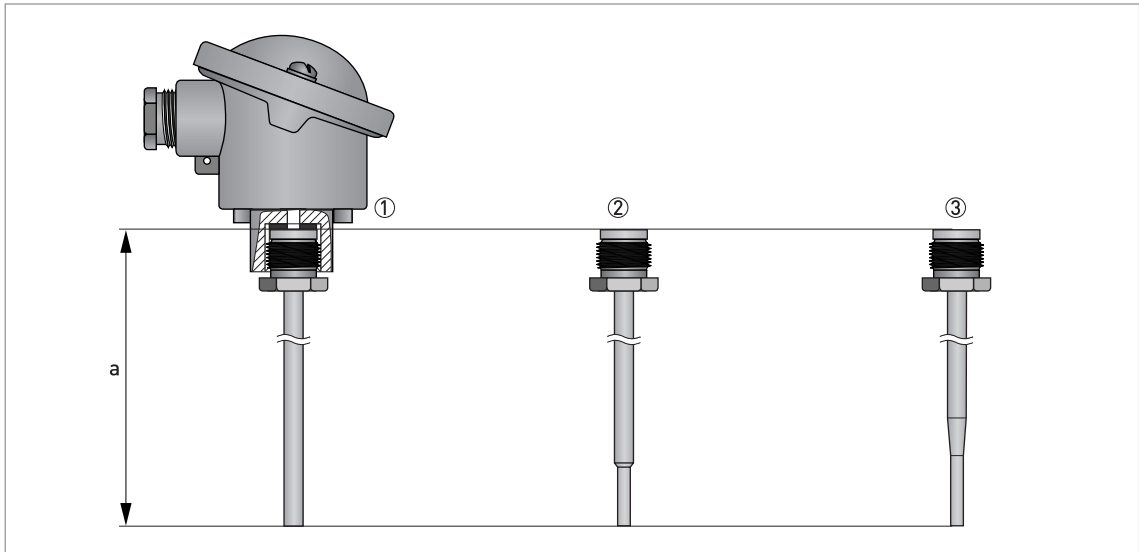

- ① TRA/TCA-P10  
 ② TRA/TCA-P20  
 ③ TRA/TCA-P40

*The following applies when determining the length of the measuring insert for insertion-type thermometers: length of the thermowell + 10 mm / 0.39".*

TRA/TCA-P10 and -P20				
"a" (thermowell length)		Measuring insert length		
[mm]	["]	[mm]	["]	
305	12.01	315	12.40	
395	15.55	405	15.94	
545	21.46	555	21.85	

TRA/TCA-P40				
"a" (thermowell length)		Measuring insert length		
[mm]	["]	[mm]	["]	
307	12.09	317	12.48	
367	14.45	377	14.84	
427	16.81	437	17.20	

**Threaded thermometer without neck tube**

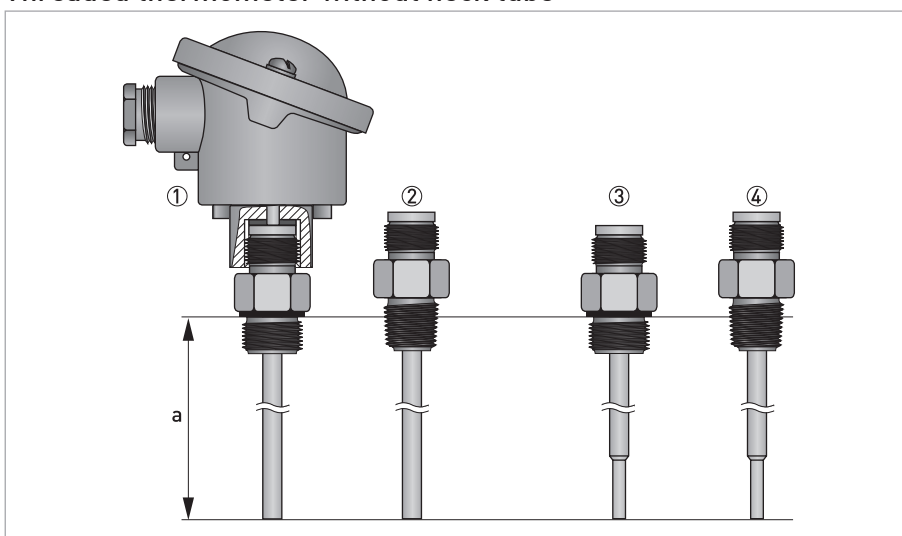

- ① TRA/TCA-S11 (G thread)
- ② TRA/TCA-S11 (NPT thread)
- ③ TRA/TCA-S21 (G thread)
- ④ TRA/TCA-S21 (NPT thread)

The insertion length for threaded thermometers without neck tube is the distance from the underside of the seal (G thread) or two-thirds of the thread height from the bottom (NPT thread) to the tip of the thermowell. The following formula determines the measuring insert length:  $insertion\ length + 45\ mm / 1.77"$ .

TRA/TCA-S11 and -S21 (G and NPT thread)				
Insertion length "a" (all versions)		Measuring insert length		
[mm]	["]	[mm]	["]	
75	2.95	120	4.72	
100	3.94	145	5.71	
115	4.53	160	6.30	
270	10.93	315	12.40	
390	15.35	435	17.13	

## Threaded thermometer with neck tube

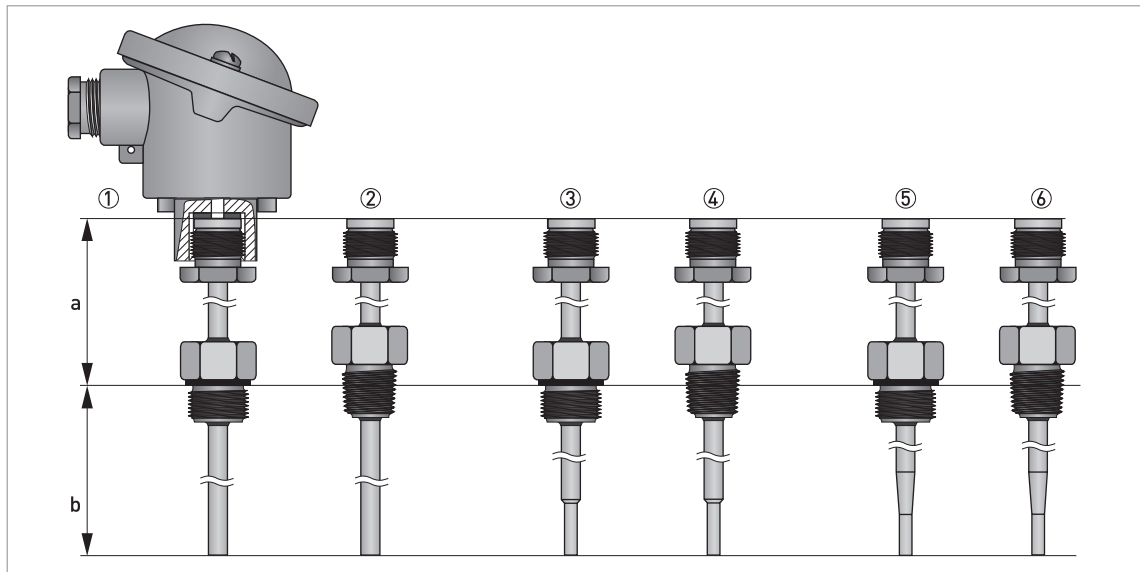

- ① TRA/TCA-S12 (G thread)
- ② TRA/TCA-S12 (NPT thread)
- ③ TRA/TCA-S22 (G thread)
- ④ TRA/TCA-S22 (NPT thread)
- ⑤ TRA/TCA-S41 (G thread)
- ⑥ TRA/TCA-S41 (NPT thread)

The insertion length for threaded thermometers with a neck tube is the distance from the underside of the seal (G thread) or two-thirds of the thread height from the bottom (NPT thread) to the tip of the thermowell. The following formula determines the measuring insert length: neck tube length + insertion length + 10 mm / 0.39".

The following applies to the neck tube length of the threaded thermometer with neck tube:

- TRA/TCA-S12 and S22: "a" regardless of process connection always 145 mm / 5.71".
- TRA/TCA-S41: "a" regardless of process connection always 147 mm / 5.79".

Versions TRA/TCA-S12 and -S22					
Insertion length "b"		Thermowell length "a + b"		Measuring insert length	
[mm]	["]	[mm]	["]	[mm]	["]
160	6.30	305	12.01	315	12.40
250	9.84	395	15.55	405	15.94
400	15.75	545	21.46	555	21.85

Version TRA/TCA-S41					
Insertion length "b"		Thermowell length "a + b"		Measuring insert length	
[mm]	["]	[mm]	["]	[mm]	["]
160	6.30	307	12.09	317	12.40
220	8.66	367	14.45	377	14.76
280	11.02	427	16.81	437	17.13

Flange thermometer

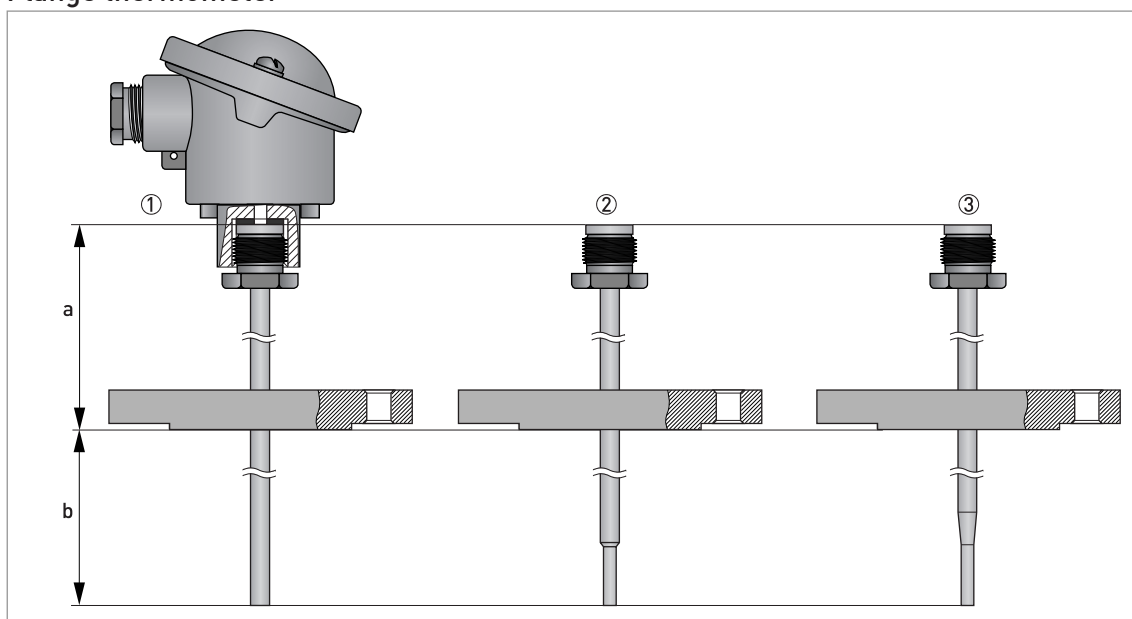

- ① TRA/TCA-F13
- ② TRA/TCA-F23
- ③ TRA/TCA-F42

The insertion length for flange thermometers is the distance from the underside of the flange to the tip of the thermowell. The following formula determines the measuring insert length: neck tube length + insertion length + 10 mm / 0.39".

The following applies to the neck tube length of the flange thermometer:

- TRA/TCA-F13 and -F23: "a" always 80 mm / 3.15".
- TRA/TCA-F42: "a" always 82 mm / 3.23".

Versions TRA/TCA-F13 and -F23					
Insertion length "b"		Thermowell length "a + b"		Measuring insert length	
[mm]	["]	[mm]	["]	[mm]	["]
225	8.86	305	12.01	315	12.40
315	12.40	395	15.55	405	15.94
465	18.31	545	21.46	555	21.85

Versions TRA/TCA-F42					
Insertion length "b"		Thermowell length "a + b"		Measuring insert length	
[mm]	["]	[mm]	["]	[mm]	["]
225	8.86	307	12.09	317	12.40
285	11.22	367	14.45	377	14.76
345	13.58	427	16.81	437	17.13

#### Insertion-type thermometer without thermowell (TRA-P14, TCA-P14)

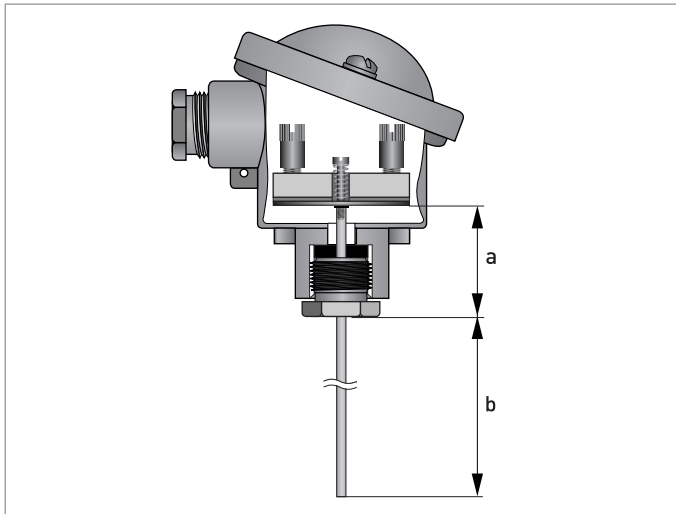

Versions TRA/TCA-P14					
Length "a"		Insertion length "b"		Measuring insert length "a + b"	
[mm]	["]	[mm]	["]	[mm]	["]
20	0.79	295	11.61	315	12.40
20	0.79	385	15.16	405	15.94
20	0.79	535	21.06	555	21.85

2.2.3 Threaded sleeve

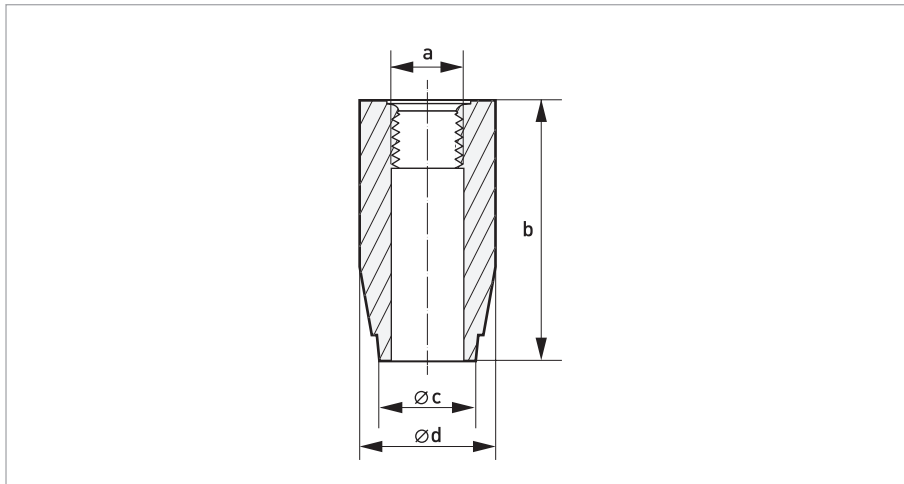

	[mm]	["]
a (thread)	12.7	G½
b	50 / 100	1.97 / 3.94
c	29	1.14
d	40	1.57

## 2.2.4 Thermowells: Diameter, wall thickness, tips

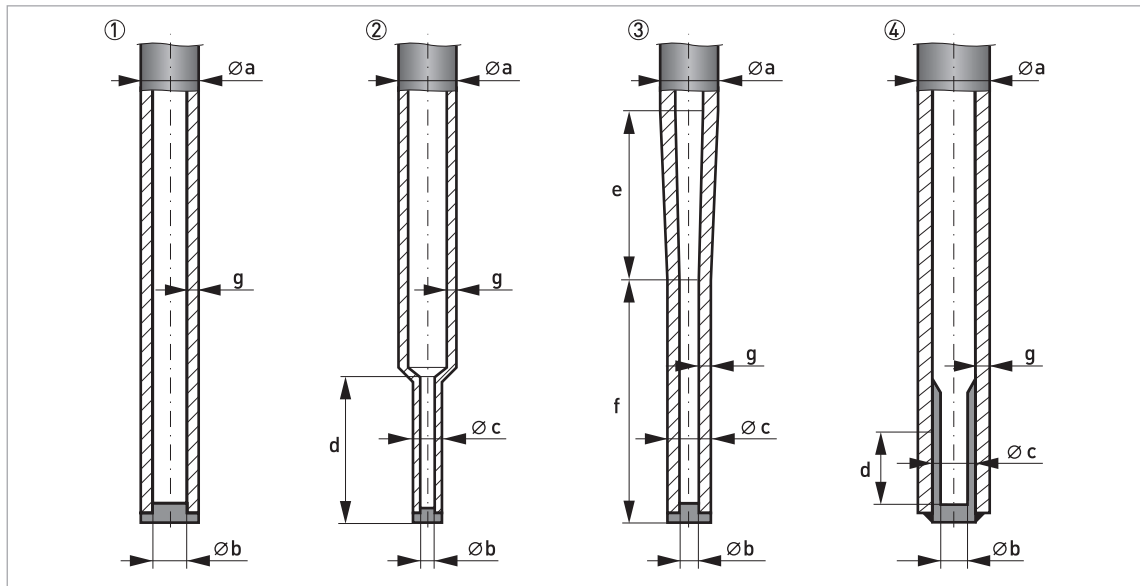

- ① Straight thermowell tip (standard)
- ② Reduced thermowell tip
- ③ Tapered thermowell tip
- ④ Straight thermowell tip (only for material 1.4404 / 316 L)

## Dimensions (material 1.4571 / 316 Ti)

	Tip ①		Tip ②		Tip ③	
	[mm]	["]	[mm]	["]	[mm]	["]
a	9 / 11 / 12	0.35 / 0.43 / 0.47	11 / 12	0.43 / 0.47	12	0.47
b	7	0.28	3.1	0.12"	6.1	0.16
c	-	-	6	0.24"	9	0.35
d	-	-	30	1.18"	-	-
e	-	-	-	-	35	1.38
f	-	-	-	-	50	1.97
g	1 / 2 / 2.5	0.04 / 0.08 / 0.10	2 / 2.5	0.08 / 0.10	≥ 1.45	0.06

## Dimensions (material 1.4404 / 316 L)

	Tip ④	
	[mm]	["]
a	10 / 12	0.39 / 0.47
b	6.1	0.24
c	8 / 8	0.31 / 0.31
d	30	1.18
g	1 / 2	0.04 / 0.08

## 2.2.5 Flanges

Upon request the manufacturer can supply flanges with dimensions other than those specified here.

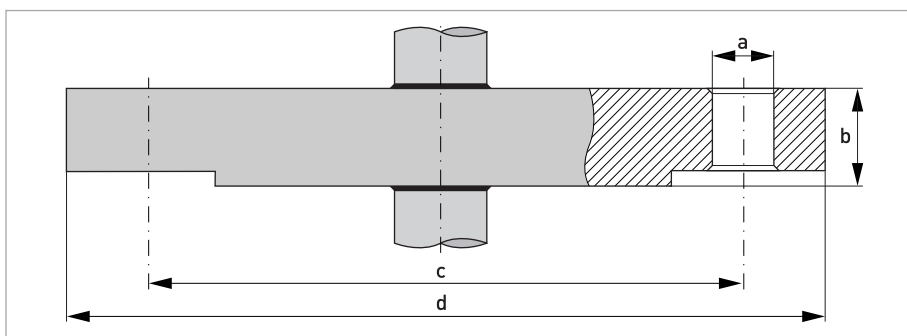

Dimensions of flange acc. to DIN EN 1092-1, raised face B1

Type of flange	a		b		c		d	
	[mm]	["]	[mm]	["]	[mm]	["]	[mm]	["]
B1-DN25 / PN40 (EN 1092-1)	14	0.55	18	0.71	85	3.35	115	4.53
B1-DN50 / PN40 (EN 1092-1)	18	0.71	20	0.79	125	4.92	165	6.50

Dimensions of flange acc. to ASME/ANSI 16.5, raised face RF

Type of flange	a		b		c		d	
	[mm]	["]	[mm]	["]	[mm]	["]	[mm]	["]
RF 1" / 150 lb (ASME B16.5)	15.9	0.63	14.7	0.58	79.4	3.13	110	4.33
RF 1" / 300 lb (ASME B16.5)	19.1	0.75	17.9	0.70	88.9	3.5	125	4.92
RF 1½" / 150 lb (ASME B16.5)	15.9	0.63	17.9	0.70	98.4	3.87	125	4.92
RF 1½" / 300 lb (ASME B16.5)	22.3	0.88	21.1	0.83	114.3	4.5	155	6.10

## 2.3 Measuring accuracy

The measuring accuracy depends largely on the following factors:

- The version of the measuring insert (type of sensor, type of circuit, measuring range).
- The correct dimensions (diameter, wall thickness) and insertion length of the thermowell for good thermal coupling to the process temperature (insufficient insertion depth often results in measurement errors).
- The type of temperature transmitter used.

*Please consult the appropriate handbook for further information regarding the accuracy of the measuring inserts and the temperature transmitters.*

With the exception of the TT 60 C/R version, all of the temperature transmitters generate an analogue output signal. For this reason, the following table indicates the measuring accuracy of most of the transmitters as a percentage of the measuring range:

### Temperature transmitter

Type of temperature transmitter	Accuracy (% of the measuring range or °K)
TT 10 C/R (analogue, standard, 4...20 mA)	± 0.15%
TT 11 C/R (analogue, 3- or 4-wire circuit: 0...10 VDC)	± 0.15%
TT 20 C/R (analogue, 4...20 mA)	± 0.10%
TT 30 C/R (digital, 4...20 mA, standard)	± 0.10%
TT 31 R (3-wire-circuit, 4...20 mA)	± 0.10%
TT 32 R (4-wire circuit, 0/4...20 mA: 0/2...10 VDC)	± 0.20%
TT 40 C/R (digital, 4...20 mA, precise)	± 0.05%
TT 50 C/R (digital, 4...20 mA, HART®)	± 0.10%
TT 51 C/R (digital, 4...20 mA, HART®, SIL2)	± 0.05%
TT 60 C/R (digital, Profibus-PA)	± 0.10°K

## 2.4 Process connections

### Insertion-type thermometer with thermowell

Process connection	Materials	Ø of thermowell	
		[mm]	["]
Clamping ring connection or compression type fitting	1.4571 / 316 Ti	9 / 11 / 12	0.35 / 0.43 / 0.47
	1.4404 / 316 L	10 / 12	0.39 / 0.47

### Insertion-type thermometer without thermowell

Process connection	Materials	Ø of immersion tube	
		[mm]	["]
Clamping ring connection or compression type fitting	1.4571 / 316 Ti 1.4404 / 316 L	6	0.24

### Threaded thermometer with and without neck tube

Process connection	Ø of thermowell (material 1.4571)		Ø of thermowell (material 1.4571)	
	[mm]	["]	[mm]	["]
G½	9 / 11 / 12	0.35 / 0.43 / 0.47	10 / 12	0.39 / 0.47
G¾	11 / 12	0.43 / 0.47		
G1				
½-14 NPT	9 / 11 / 12	0.35 / 0.43 / 0.47		
¾-14 NPT	11 / 12	0.43 / 0.47		

The manufacturer offers the flange thermometer with process connections acc. to DIN EN 1092-1 or ASME/ANSI 16.5. For DIN flanges the raised face complies with Form B1 and with ASME flanges, type "RF" or type "RTJ".

### Flange thermometer with neck tube

Process connection	Ø of thermowell (material 1.4571 / 316 Ti)		Ø of thermowell (material 1.4404 / 316 L)	
	[mm]	["]	[mm]	["]
DN25 / PN40	9 / 11 / 12	0.35 / 0.43 / 0.47	10 / 12	0.39 / 0.47
DN50 / PN40	11 / 12	0.43 / 0.47		
1" / 150 lb	9 / 11 / 12	0.35 / 0.43 / 0.47		
1½" / 150 lb	11 / 12	0.43 / 0.47		
1" / 300 lb				
1½" / 300 lb				

## 2.5 Measuring range and permitted load

To prevent fatal injuries or damage, never operate the thermometer outside of its permissible mechanical, thermal or chemical limits. For further information refer to the rest of this section and the "Technical data" section.

The information in this subsection is informative only and does not reflect the vibration load caused by flow-induced eddy shedding and the resulting vibration. If necessary, prior to purchasing and installing an industrial thermometer, have a specific strength calculation performed (e. g. as per DITTRICH or MURDOCK, ASME PTC 19.3TW-2010). For further information contact the manufacturer.

To prevent destruction or damage, only operate a thermometer without a thermowell in the range of 0.8...1.2 bara / 11.6...17.4 psia.

The manufacturer can provide an optional strength calculation for a fee.

Temperatures that can be measured with an industrial thermometer depend largely on the load of the thermometer. Load limits are defined through a variety of factors (see the subsection "Load limits" in the "Installation" section). For this reason, the manufacturer cannot make any universally valid statements about the measuring range and permissible load.

### Operating limits of thermowells, material 1.4571 / 316 Ti (Ø 9 x 1 mm / 0.35 x 0.04")

Process connection	Insertion length		p <sub>max</sub> at +20°C / +400°C (+68°F / +752°F), air		p <sub>max</sub> at +20°C / +400°C (+68°F / +752°F), Water (steam)	
	[mm]	["]	[bar]	[psi]	[bar]	[psi]
Thread G½, G¾, G1, ½-14 NPT, ¾-14 NPT	160	6.3	50 / 36	725 / 522	50 / 50	725 / 725
	250	9.8	28.9 / 33.7	419 / 489	50 / 50	725 / 725
	400	15.7	11.7 / 13.9	170 / 204	9.9 / 33	861 / 479
Flanges DN25 and 50 (PN40)	160...250	6.3...9.8	28.9 / 23.7	419 / 344	40 / 23.7	580 / 344
	400	15.7	11.7 / 13.9	170 / 202	9.9 / 23.7	144 / 344
Flanges ASME 1" and 1½" (150 lb)	160...250	6.3...9.8	19 / 6.5	276 / 94	19 / 6.5	276 / 94
	400	15.7	11.7 / 6.5	170 / 94	9.9 / 6.5	144 / 94
Flanges ASME 1" and 1½" (300 lb)	160	6.3	49.6 / 29.4	719 / 426	49.6 / 29.4	719 / 426
	250	9.8	28.9 / 29.4	419 / 426	49.6 / 29.4	719 / 426
	400	15.7	11.7 / 13.9	170 / 202	9.9 / 29.4	144 / 426

- Straight thermowell
- Air flows against the thermometer at 25 m/s or 82 ft/s or water (steam) at 3 m/s or 9.8 ft/s

## Operating limits of thermowells, material 1.4571 / 316 Ti (Ø 11 x 2 mm / 0.43 x 0.08")

Process connection	Insertion length		p <sub>max</sub> at +20°C / +400°C (+68°F / +752°F), air		p <sub>max</sub> at +20°C / +400°C (+68°F / +752°F), Water (steam)	
	[mm]	["]	[bar]	[psi]	[bar]	[psi]
Thread G½, G¾, G1, ½-14 NPT, ¾-14 NPT	160	6.3	70 / 84	1015 / 1218	100 / 100	1450 / 1450
	250	9.8	27.8 / 34.4	403 / 499	100 / 100	1450 / 1450
Flanges DN25 and 50 (PN40)	160...250	6.3...9.8	40...27.8 / 23.7 ①	580...403 / 344 ①	40...27.8 / 23.7 ①	580...403 / 344 ①
Flanges ASME 1" and 1½" (150 lb)	160...250	6.3...9.8	19 / 6.5	276 / 94	19 / 6.5	276 / 94
Flanges ASME 1" and 1½" (300 lb)	160	6.3	49.6 / 29.4	719 / 426	49.6 / 29.4	719 / 426
	250	9.8	27.8 / 29.4	403 / 426	27.8 / 29.4	403 / 426

- Straight thermowell and thermowell with reduced tip
- Air flows against the thermometer at 40 m/s or 131.2 ft/s or water (steam) at 5 m/s or 16.4 ft/s

① At +400°C / +752°F this maximum value applies regardless of insertion length.

## Operating limits of thermowells, material 1.4571 / 316 Ti (Ø 12 x 2.5 mm / 0.47 x 0.19")

Process connection	Insertion length		p <sub>max</sub> at +20°C / +400°C (+68°F / +752°F), air		p <sub>max</sub> at +20°C / +400°C (+68°F / +752°F), Water (steam)	
	[mm]	["]	[bar]	[psi]	[bar]	[psi]
Thread G½, G¾, G1, ½-14 NPT, ¾-14 NPT	160	6.3	87 / 100	1261 / 1450	100 / 100	1450 / 1450
	220	8.7	48 / 59	696 / 856	100 / 100	1450 / 1450
	280	11	28.5 / 35.4	413 / 513	100 / 100	1450 / 1450
Flanges DN25 and 50 (PN40)	160	6.3	40 / 23.7	580 / 344	40 / 23.7	580 / 344
	280	11	28.5 / 23.7	413 / 344	28.5 / 23.7	413 / 344
Flanges ASME 1" and 1½" (150 lb)	160...280	6.3...11	19 / 6.5	276 / 94	19 / 6.5	276 / 94
Flanges ASME 1" and 1½" (300 lb)	160	6.3	49.6 / 29.4	719 / 426	49.6 / 29.4	719 / 426
	280	11	28.5 / 29.4	413 / 426	28.5 / 29.4	413 / 426

- Straight thermowell and thermowell with reduced or tapered tips
- Air flows against the thermometer at 40 m/s or 131.2 ft/s or water (steam) at 5 m/s or 16.4 ft/s

**Operating limits of thermowells, material 1.4404 / 316 L (Ø 10 x 1 mm / 0.39 x 0.04")**

Process connection	Insertion length		p <sub>max</sub> at +20°C / +400°C (+68°F / +752°F), air		p <sub>max</sub> at +20°C / +400°C (+68°F / +752°F), Water (steam)	
	[mm]	["]	[bar]	[psi]	[bar]	[psi]
Thread G½, G¾, G1, ½-14 NPT, ¾-14 NPT	160	6.3	34 / 40.4	493 / 586	100 / 96	1450 / 1392
	250	9.8	14.6 / 18	212 / 261	30 / 75	435 / 1088
Flanges DN25 and 50 (PN40)	160...250	6.3...9.8	34...14.6 / 25.7...18	493...212 / 373...261	34...14.6 / 25.7...18	493...212 / 373...261
Flanges ASME 1" and 1½" (150 lb)	160...250	6.3...9.8	15.9...14.6 / 6.5 ①	231...212 / 94 ①	15.9...14.6 / 6.5 ①	231...212 / 94 ①
Flanges ASME 1" and 1½" (300 lb)	160	6.3	34 / 24.3	493 / 352	34 / 24.3	493 / 352
	250	9.8	14.6 / 18	212 / 261	14.6 / 18	212 / 261

- Straight thermowell and thermowell with reduced tip
- Air flows against the thermometer at 40 m/s or 131.2 ft/s or water (steam) at 5 m/s or 16.4 ft/s

① At +400°C / +752°F this maximum value applies regardless of insertion length.

**Operating limits of thermowells, material 1.4404 / 316 L (Ø 12 x 2 mm / 0.47 x 0.08")**

Process connection	Insertion length		p <sub>max</sub> at +20°C / +400°C (+68°F / +752°F), air		p <sub>max</sub> at +20°C / +400°C (+68°F / +752°F), Water (steam)	
	[mm]	["]	[bar]	[psi]	[bar]	[psi]
Thread G½, G¾, G1, ½-14 NPT, ¾-14 NPT	160	6.3	73 / 86	1059 / 1247	100 / 100	1450 / 1450
	220	8.7	40.2 / 49.1	583 / 712	100 / 100	1450 / 1450
	280	11	25.3 / 31.3	367 / 454	100 / 100	1450 / 1450
Flanges DN25 and 50 (PN40)	160	6.3	40 / 25.7	580 / 373	40 / 25.7	580 / 373
	280	11	25.3 / 25.7	367 / 373	40 / 25.7	580 / 373
Flanges ASME 1" and 1½" (150 lb)	160...280	6.3...11	15.9 / 6.5 ①	231 / 94 ①	15.9...41.4 / 6.5...24.3	231...600 / 94...352
Flanges ASME 1" and 1½" (300 lb)	160	6.3	40 / 24.3	580 / 352	41.4 / 24.3	600 / 352
	280	11	25.3 / 24.3	367 / 352	41.4 / 24.3	600 / 352

- Straight thermowell and thermowells with reduced or tapered tips
- Air flows against the thermometer at 40 m/s or 131.2 ft/s or water (steam) at 5 m/s or 16.4 ft/s

① Both maximum values apply regardless of insertion length.

## 2.6 Permissible temperatures

### 2.6.1 Connection head

Temperature transmitter	Connection head		Temperature range	Maximum temperature limiting component
	Material	Display		
without	Metal	no	-40...+100°C / -40...+212°F	Gasket of connection head cover and cable gland
without	Plastic	no	-40...+80°C / -40...+176°F	Connection head material
with	Metal	no	-40...+85°C / -40...+185°F	Temperature transmitter
with	Plastic	no	-40...+80°C / -40...+176°F	Connection head material
with	Metal	Yes	-40...+70°C / -40...+158°F	Display

### 2.6.2 Unloaded thermowell and immersion tubes

The temperatures specified in the following tables are valid only for thermowells and immersion tubes that do not project into flowing media or media under pressure. The maximum permissible temperature is reduced under load.

*If you are unsure as to whether the device can withstand the loads of the process when using an insertion-type thermometer without thermowell, have a separate strength calculation done (e.g. per DITTRICH or MURDOCK, ASME PTC 10.9-TW)! For further information contact the manufacturer.*

*The manufacturer can provide an optional strength calculation for a fee.*

#### Thermowells

Type of thermowell	Material	Permissible temperature range
All	1.4571 / AISI 316 Ti (standard)	-200...+600°C / -328...+1112°F
	1.4404 / AISI 316 L (standard)	-200...+600°C / -328...+1112°F
	1.4841 / AISI 314/310 (optional)	0...+1000°C / +32...+1832°F

#### Sheaths of measuring inserts made of mineral insulated cable

Type of sensor	Cable jacket material	Permissible temperature range
Pt100 RTD	1.4404 / AISI 316 L	-200...+600°C / -328...+1112°F
Thermocouple	Inconel® 600	-40...+1100°C / -40...+1832°F

## 2.7 Sensor response times

Thermometer response times are generally indicated as "50% time" ( $t_{05}$ ) and "90% time" ( $t_{09}$ ). "50% time" refers to the time needed for a thermometer signal to achieve 50% of its end value in the face of erratic temperature changes (this applies analogously to "90% time").

*You can find more information about response times in VDI 3522.*

### Thermometer with thermowell, measuring insert with Pt100 RTD

Ø of thermowell		Straight thermowell		Reduced tip		Tapered tip	
[mm]	["]	$t_{05}$ [s]	$t_{09}$ [s]	$t_{05}$ [s]	$t_{09}$ [s]	$t_{05}$ [s]	$t_{09}$ [s]
9 / 10	0.35 / 0.39	17	52	Not available		Not available	
11	0.43	21	58	8	22	Not available	
12	0.47	22	66	10	26	12	30

Water flows against the thermometer at 0.4 m/s or 1.31 ft/s

### Thermometer with thermowell, measuring insert with thermocouple

Ø of thermowell		Straight thermowell		Reduced tip		Tapered tip	
[mm]	["]	$t_{05}$ [s]	$t_{09}$ [s]	$t_{05}$ [s]	$t_{09}$ [s]	$t_{05}$ [s]	$t_{09}$ [s]
9 / 10	0.35 / 0.39	14	42	Not available		Not available	
11	0.43	17	46	7	18	Not available	
12	0.47	18	54	8	21	10	24

Water flows against the thermometer at 0.4 m/s or 1.31 ft/s

### Thermometer without thermowell (TRA/TCA-P14 with Ø 6 mm / 0.24")

Sensor	Water with 0.4 m/s or 1.31 ft/s		Air with 1 m/s or 3.28 ft/s	
	$t_{05}$ [s]	$t_{09}$ [s]	$t_{05}$ [s]	$t_{09}$ [s]
Pt100 RTD	3.5	8	24	54
Thermocouple	2.5	7	21	50

## 2.8 Limiting values for clamping ring connection and compression type fittings

Material	Maximum process temperature		Maximum pressure at a process temperature of +20°C / +68°F	
	[°C]	[°F]	[bar]	[psi]
PTFE	+200	+392	10	145
Steel	+400	+752	25	362.6

### 3.1 Intended use

*Responsibility for the use of the measurement devices with regard to suitability, intended use and corrosion resistance of the used materials against the measured fluid lies solely with the operator.*

*The manufacturer is not liable for any damage resulting from improper use or use for other than the intended purpose.*

The thermometer is used to measure the temperature of gases, liquids, vapour and solids in industrial applications. The devices are particularly suited to the measurement of

- liquids with low viscosity,
- water and chemicals with low corrosiveness,
- saturated steam and superheated steam.

### 3.2 General notes on installation

*For devices used in hazardous areas, additional safety notes apply; please refer to the Ex documentation.*

*Installation, assembly, start-up and maintenance may only be performed by appropriately trained personnel. The regional occupational health and safety directives must always be observed.*

*Inspect the cartons carefully for damages or signs of rough handling. Report damage to the carrier and to the local office of the manufacturer.*

*Do a check of the packing list to make sure that you have all the elements given in the order.*

*Look at the device nameplate to ensure that the device is delivered according to your order.*

*Assembly materials and tools are not part of the delivery. Use the assembly materials and tools in compliance with the applicable occupational health and safety directives.*

### 3.3 Storage

*Always store industrial thermometers in a dry place protected from dust. The permissible range for storage temperatures is  $-40...+70^{\circ}\text{C}$  /  $-40...+176^{\circ}\text{F}$ .*

### 3.4 Transport

*Always transport industrial thermometers in their original packaging. Do not expose the devices to moisture or vibration during transport. The information that applies to storage also applies to transport.*

## 3.5 Proper installation

Take the following points into consideration prior to installing the thermometer:

- The dimensions of the thermowell (length, diameter, wall thickness, type of tip) comply with the requirements of the measuring point. The mechanical load as a result of flowing media, vibration and resonances is the focus here. In addition, incorrect dimensions can lead to measurement errors.
- The thermowell is sufficiently resistant to chemically aggressive media (refer to the generally accessible corrosion tables). Otherwise, corrosion may occur or the medium may penetrate into the thermowell. When in doubt, select a thermowell made from the same material as your system.

### 3.5.1 Possible installations

Installations include the parameters "installation site", "installation angle" and "insertion length". Depending on the space available and the diameter of the pipe, three installations are recommended for pipes with flowing product:

- Small pipe diameter: Installation directly against the direction of flow in a bend in the pipe (①).
- Small pipe diameter: Installation diagonally against the direction of flow, if a bend in the pipe is available (②).
- Large pipe diameter: Vertical installation, if flow-induced periodic vortex shedding does not cause the thermometer to vibrate in its resonance frequency (③).

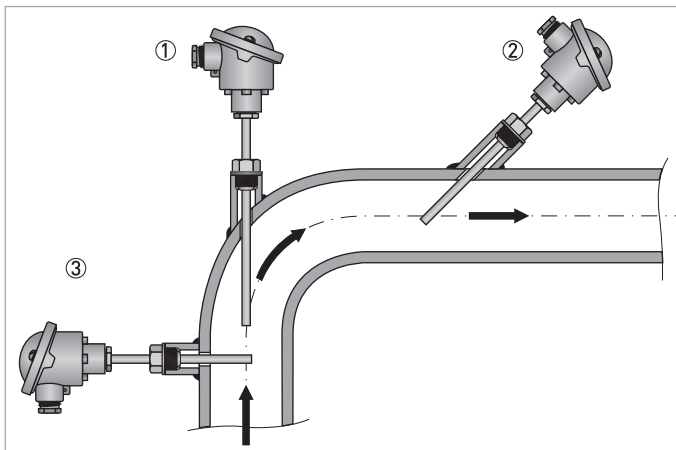

Figure 3-1: Recommended installations

### Permitted insertion length of the thermowell or measuring insert

The "insertion length" of the thermowell or measuring insert refers to the distance from the seal of the process connection (for G threads), two-thirds of the thread height (for NPT threads) or the bottom of the flange (for flange thermometers) to the tip of the thermowell or sheath. This length determines how far the sensor projects into the measured medium.

To avoid measurement errors, ensure that the insertion length ("b" in the drawing below) meets the following requirements:

- Insertion length = 10...15 x thermowell diameter, but at least 100 mm / 3.94" (shorter insertion lengths are possible but they impair measuring accuracy).
- Tubes with  $\varnothing < 300$  mm / 11.8": thermowell tip should project past the middle of the pipe is possible, if the flow velocity of the product allows it.

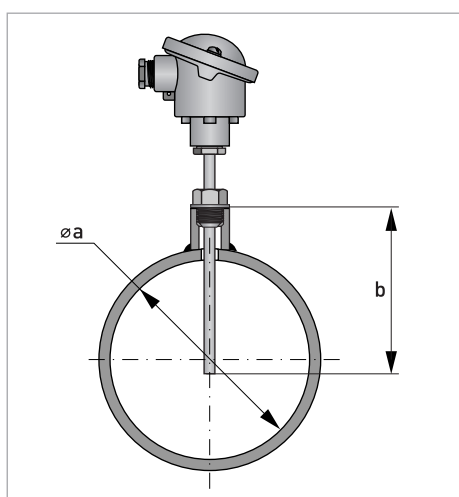

Figure 3-2: Permitted insertion length

*For more information on the maximum insertion length, please refer to the subsection "Typical load types".*

### 3.5.2 Other installation requirements

*When a seal is damaged or incorrect, the medium may leak out, causing material damage or bodily harm! It is the sole responsibility of the operator to select the right seal.*

- A well-insulated pipeline or tank around the measuring point reduces the heat transfer and the distorting influence of the ambient temperature.
- To avoid measurement errors caused by poor heat transfer, the measuring insert must always be in contact with the bottom of the thermowell (this is normally guaranteed by the spring-loaded version of the measuring insert).
- Choosing the right gasket for the process connection depends on the process conditions; the manufacturer can thus only give the general recommendation that the gasket must comply with the individual requirements of the measuring point (e.g. pressure, temperature, chemically aggressive media).

## 3.6 Load limits

The load limits of industrial thermometers depend on several factors:

- Dimensions and design of the thermowell (especially the insertion length and diameter)
- Thermowell material
- Mechanical conditions the thermowell is subject to due to the measured medium (pressure, temperature, flow velocity, viscosity, density)
- Sealable pressure of the process connection
- Vibration load

*The "sealable pressure" is the maximum pressure the process connection can seal against.*

The sheer number of factors at play illustrates the difficulty in making universally valid statements about the load limits. The diagrams in the next subsection serve as an initial assessment.

### 3.6.1 Typical load types

*To prevent destruction or damage, never operate the thermometer outside of its permissible mechanical, thermal or chemical limits. For further information refer to the rest of this section and the "Technical data" section.*

*The information in this subsection is informative only and does not reflect the vibration load caused by flow-induced eddy shedding and the resulting vibration. If necessary, prior to purchasing and installing an industrial thermometer, have a specific strength calculation performed (e. g. as per DITTRICH or MURDOCK, ASME PTC 19.3TW-2010). For further information contact the manufacturer.*

*The manufacturer can provide an optional strength calculation for a fee.*

The first diagram applies to the following thermometer:

- TRA/TCA-P10, -S11/12, -F13: straight thermowells according to DIN 43772 (Forms 2, 2G and 2F)
- $\varnothing$  11 x 2 mm / 0.43 x 0.08"
- Material 1.4571 / 316 Ti

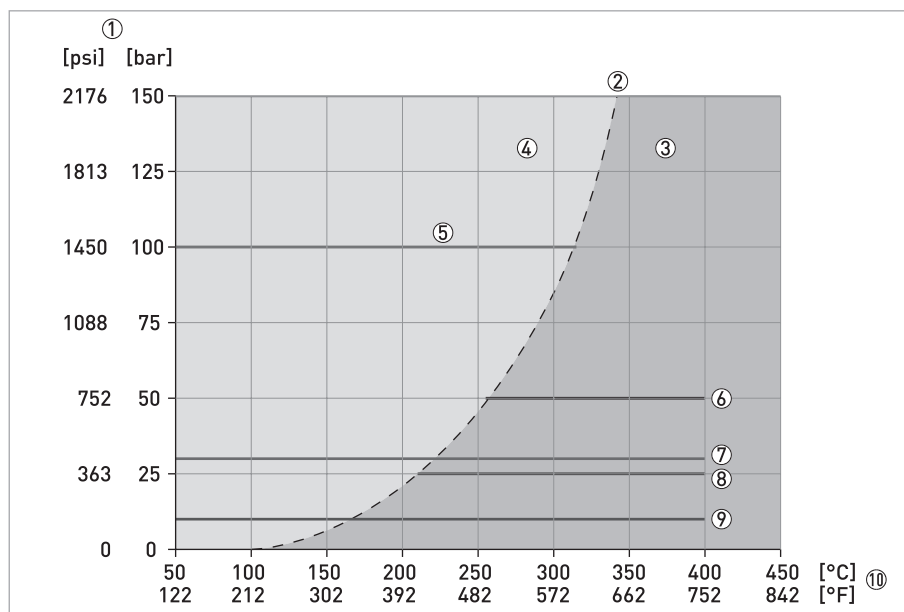

Figure 3-3: Load diagram for TRA/TCA-P10, -S11/12, -F13

- ① Pressure of the measured medium
- ② Steam pressure curve
- ③ Steam
- ④ Water
- ⑤ Insertion length 250...400 mm or 9.84...15.75"; water with 3 m/s or 9.8 ft/s
- ⑥ Insertion length 250 mm or 9.84"; steam with 40 m/s or 131.2 ft/s
- ⑦ Insertion length 250 mm or 9.84"; air with 40 m/s or 131.2 ft/s
- ⑧ Insertion length 400 mm or 15.75"; steam with 40 m/s or 131.2 ft/s
- ⑨ Insertion length 400 mm or 15.75"; air with 40 m/s or 131.2 ft/s
- ⑩ Temperature of the measured medium

The second diagram applies to the following thermometer:

- TRA/TCA-P40, -S41, -F42: thermowells with tapered tip according to DIN 43772 (Forms 3, 3G and 3F)
- $\varnothing$  12 x 2.5 mm / 0.47 x 0.10"
- Material 1.4571 / 316 Ti

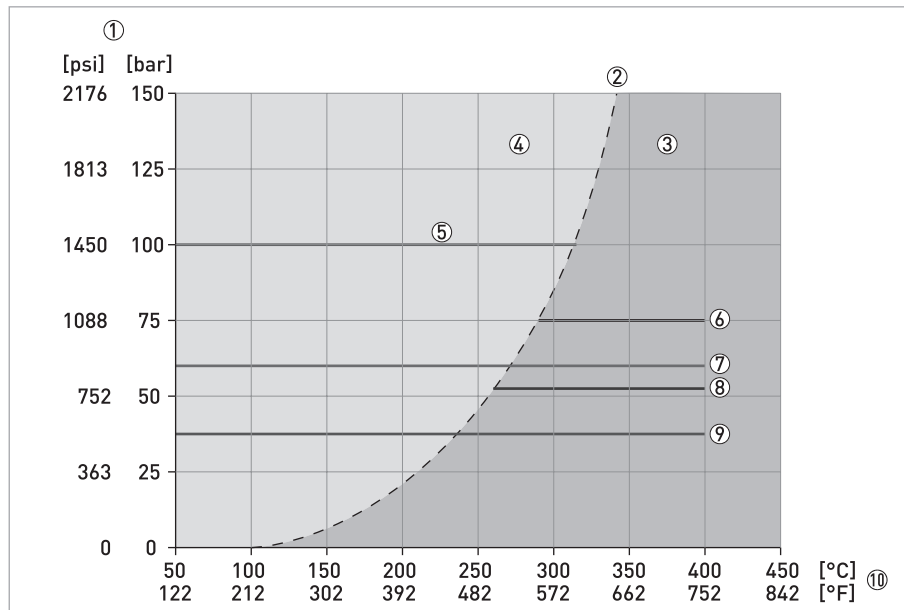

Figure 3-4: Load diagram for TRA/TCA-P40, -S41, -F42

- ① Pressure of the measured medium
- ② Steam pressure curve
- ③ Steam
- ④ Water
- ⑤ Insertion length 220...280 mm or 8.66...11.02"; water with 3 m/s or 9.8 ft/s
- ⑥ Insertion length 220 mm or 8.66"; steam with 40 m/s or 131.2 ft/s
- ⑦ Insertion length 220 mm or 8.66"; air with 40 m/s or 131.2 ft/s
- ⑧ Insertion length 280 mm or 11.02"; steam with 40 m/s or 131.2 ft/s
- ⑨ Insertion length 280 mm or 11.02"; air with 40 m/s or 131.2 ft/s
- ⑩ Temperature of the measured medium

### 3.6.2 Vibration load

*Permanently operating the thermowell in its natural resonance can quickly damage or destroy the thermometer! So, prior to installation, ensure that this does not happen and select a thermowell with a different length, a different diameter or another material if necessary.*

All thermometers that feature a thermowell and neck tube and are attached to the process connection have two components that can vibrate: the thermowell and the connection head with the neck tube. That is why the terms "thermowell resonance" and "head resonance" are commonly heard.

A thermowell surrounded by the measured medium is a body behind which vortices periodically are released ("Kármán vortex street"). If the frequency of the vortex detachment is equal to the resonance frequency of the thermowell, it starts to vibrate. If this happens for a short period of time, such as when starting up the system and the frequency of the vortex detachment passes through the resonance range of the thermowell, there is generally no damage is caused. The opposite is true, however, if the vibrations remain permanently in the resonance range.

### 3.6.3 Temperature load

The temperature of the measured medium and the thermal dissipation via thermowell and neck tube also cause the connection head to heat up. After some time, the interior of the connection head and any existing head-mounted transmitter heat up to the temperature of the housing. This occurs in thermometers with and without neck tubes. A neck tube, however, causes thermal decoupling and can prevent the connection head or temperature transmitter from overheating at high process temperatures.

*When the temperature is too high, the connection head and the components found in it (e. g. temperature transmitter or display) can be damaged or destroyed! It is your responsibility as the operator to ensure that the connection head does not get too hot. If this does happen, select another installation site or a thermometer with a neck tube or, with insertion-type thermometers, increase the distance between the connection head and the process connection.*

*Sometimes even a neck tube cannot prevent the maximum permissible temperature in the connection head from being exceeded! It does cause extensive thermal decoupling of the connection head but you still have to always take into consideration the installation situation as well as the ambient and process temperatures!*

The following diagram will aid in the selection of the right neck tube length and shows how the process temperature and the neck tube length impact the temperature of the connection head:

*The diagram only shows the amount by which the temperature of the connection head increases. To determine the actual temperature of the connection head you must add the ambient temperature to it in a second step!*

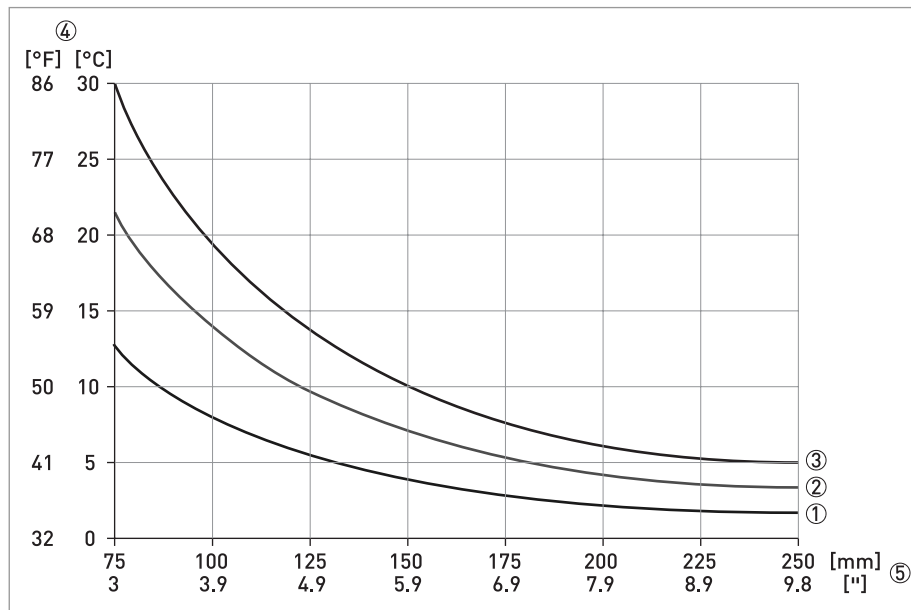

Figure 3-5: Heating of the connection head

- ① Process temperature +220°C / +428°F
- ② Process temperature +400°C / +752°F
- ③ Process temperature +570°C / +1058°F
- ④ Temperature of the connection head
- ⑤ Neck tube length

*For more information regarding the maximum allowable temperatures, please refer to the "Technical Data" section.*

## 3.7 Installation notes on the individual device classes

### 3.7.1 Insertion-type thermometer

Insertion-type thermometers can be installed in three different ways:

- Insert
- Fixation with a clamping ring connection or compression type fitting
- Weld in

#### Clamping ring connection

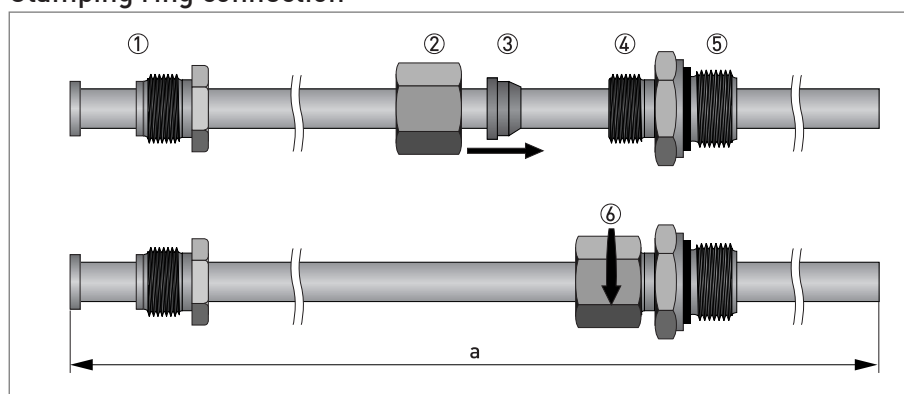

- ① Thread to screw into the connection head
- ② Union nut
- ③ Clamping ring
- ④ Thread for the union nut
- ⑤ Process thread
- ⑥ Tightened union nut

*Note that compression fittings with plastic rings are less resistant to pressure and temperature than compression fittings with metal rings! For information regarding the limit values of compression fittings, refer to the "Technical Data" section.*

*A thermometer that is weld in allows for higher process pressures and temperatures than thermometers attached with clamping ring connections.*

For fixing, the manufacturer offers two types of clamping ring connections with the threads G $\frac{1}{2}$ , G $\frac{3}{4}$ , G1,  $\frac{1}{2}$ -14 NPT or  $\frac{3}{4}$ -14 NPT (measurement "a" in the following drawing is the "insertion length"):

- Using a metal ring clamped to the thermowell or measuring insert to prevent any subsequent movement, thus preventing any change in the immersion depth
- Using a plastic ring which can subsequently move on the thermowell or measuring insert, allowing changes in the immersion depth

### 3.7.2 Threaded thermometer

A threaded thermometer can be installed two different ways:

- Screwed in directly: Pipes with a wall thickness  $\geq 20$  mm / 0.8" make it possible to drill a hole and cut a thread.
- Screw into threaded sleeves: Pipes with a wall thickness  $< 20$  mm require a sleeve to be welded in; these are not included in delivery but make up part of the accessories range.

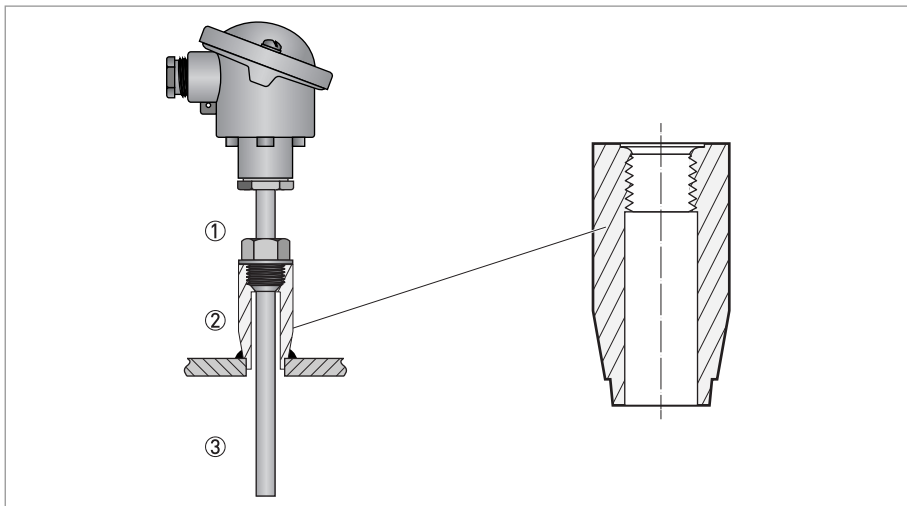

Figure 3-6: Welded sleeve for threaded thermometer

- ① Neck tube with connection head
- ② Permanently welded on threaded sleeve
- ③ Thermowell

*You, the user, are responsible for selecting a suitable sealing material for the process connection, not the manufacturer! When installing the seals to the process connection, always ensure a good fit!*

*Sometimes even a neck tube cannot prevent the maximum permissible temperature in the connection head from being exceeded! It does cause extensive thermal decoupling of the connection head but you still have to always take into consideration the installation situation as well as the ambient and process temperatures!*

*For more information on the dimensions of the threaded sleeve please see the subsection "Dimensions" in the section "Technical Data". Note that the threaded sleeve is not included in the scope of standard delivery but is an optional accessory.*

### 3.7.3 Flange thermometer

The flange thermometer can be installed using a weld neck flange, for example, as shown in the following drawing:

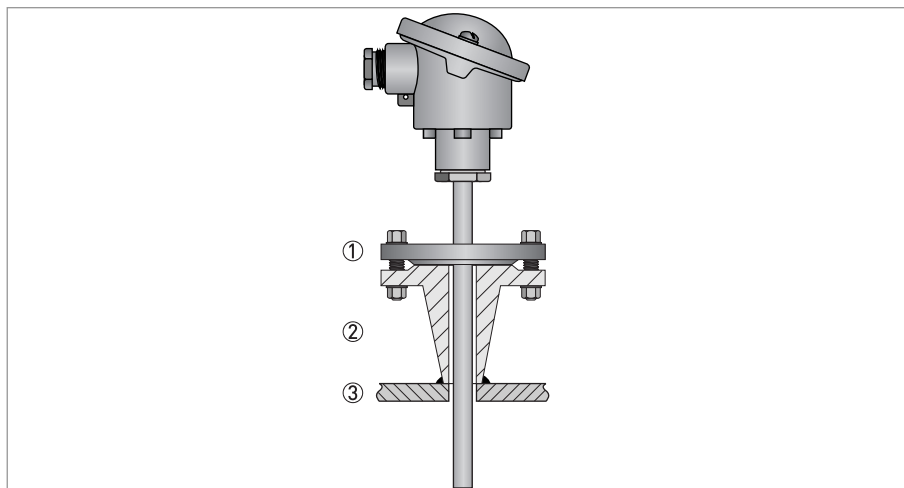

Figure 3-7: Installing a flange thermometer with a weld neck flange

- ① Thermowell with flange as process connection
- ② Weld neck flange
- ③ Pipeline or container wall

*When attaching the flange, tighten the screws evenly and crosswise to avoid leaks at the process connection.*

*You, the user, are responsible for selecting a suitable sealing material for the process connection, not the manufacturer! When installing the seals to the process connection, always ensure a good fit!*

### 3.7.4 Insertion-type thermometer without thermowell

As with the installation of an insertion-type thermometer with a thermowell, the version without a thermowell can be installed in two different ways:

- Insert
- Attachment with a clamping ring connection

You may bend measuring inserts, but be advised of the following restrictions:

*Ensure that when bending the sheath, the smallest bending radius is at least three times the diameter of the sheath! Otherwise you may damage or destroy the mineral insulated sheathed cable and thus the measuring insert.*

*Do not bend the bottom 50 mm / 2" of the sheath! This may damage or destroy the RTD or the thermocouple.*

Also keep in mind the following information regarding the maximum allowable loads:

*Only operate the industrial thermometer without a thermowell if the static process pressure is in the range of 0.8...1.2 bara / 11.6...17.4 psia! If the static process pressure is too high (over 1.2 bara / 17.4 psia) or too low (below 1.2 bara / 11.6 psia) the measuring insert may be damaged or destroyed.*

*If you are unsure as to whether the device can withstand the loads of the process when using an insertion-type thermometer without thermowell, have a separate strength calculation done (e.g. per DITTRICH or MURDOCK, ASME PTC 10.9-TW)! For further information contact the manufacturer.*

## 4.1 Safety instructions

*All work on the electrical connections may only be carried out with the power disconnected. Take note of the voltage data on the nameplate!*

*Observe the national regulations for electrical installations!*

*For devices used in hazardous areas, additional safety notes apply; please refer to the Ex documentation.*

*Observe without fail the local occupational health and safety regulations. Any work done on the electrical components of the measuring device may only be carried out by properly trained specialists.*

*Look at the device nameplate to ensure that the device is delivered according to your order.*

## 4.2 Grounding

*The thermowells on the industrial thermometer are grounded via the process connection. No additional grounding is required. One exception is the coated flange thermowells, which must be grounded separately.*

## 4.3 Protection category

The IP protection category of an industrial thermometer depends on the type of connection and the cable gland used. Connection heads with ½-14 NPT threads are supplied without cable glands. The following protection categories are available: IP54 (BKK), IP65 (BA, BUZ-T/S/H/HW, BVA), IP67 (BGK), IP68 (AXD).

## 4.4 Power supply

*Assembly materials and tools are not part of the delivery. Use the assembly materials and tools in compliance with the applicable occupational health and safety directives.*

The only components of an industrial thermometer that require a power supply are the measuring insert and any temperature transmitter used. For more detailed information on supplying these components with power, consult the product-specific manuals.

## 5.1 Type code VTS1

- The following type code is valid for TRA and TCA-P10/14/20, -S11/12/21/22 and -F13/23.
- The characters of the type code highlighted in light grey describe the standard.
- "Ex" indicates that the version in question is available in both the non-Ex and Ex version.

VTS1	4	Type
	1	TRA-P10: insertion-type resistance thermometer, Ex
	2	TRA-S11: threaded resistance thermometer, Ex
	3	TRA-S12: threaded resistance thermometer with neck tube, Ex
	4	TRA-F13: flange resistance thermometer with neck tube, Ex
	5	TRA-P20: insertion-type resistance thermometer, reduced tip
	6	TRA-S21: threaded resistance thermometer, reduced tip
	7	TRA-S22: threaded thermometer with neck tube, reduced tip
	8	TRA-F23: flange resistance thermometer with neck tube, reduced tip
	A	TCA-P10: insertion-type thermocouple, Ex
	B	TCA-S11: threaded thermocouple, Ex
	C	TCA-S12: threaded thermocouple with neck tube, Ex
	D	TCA-F13: flange thermocouple with neck tube, Ex
	E	TCA-P20: insertion-type thermocouple, reduced tip
	F	TCA-S21: threaded thermocouple, reduced tip
	G	TCA-S22: threaded thermocouple with neck tube, reduced tip
	H	TCA-F23: flange thermocouple with neck tube, reduced tip
	L	TRA-P14: insertion-type thermometer without thermowell, measuring insert with Ø 6mm / 0.24" and Pt100 RTD, Ex
	T	TCA-P14: insertion-type thermometer without thermowell, measuring insert with Ø 6mm / 0.24" and thermocouple, Ex
		<b>Approval</b>
	0	None
	1	ATEX - II 1G Ex ia IIC T6 (Gas), II 1D Ex iaD 20 IP65 T140°C/284°F (Dust)
	2	ATEX - II 1G Ex ia IIC T6 (Gas), II 1D Ex iaD 20 IP65 T175°C/347°F (Dust)
	3	ATEX - II 1/2G Ex ia IIC T6 (Gas), II 1D Ex iaD 20 IP65 T140°C/284°F (Dustb)
VTS1	4	Continued on next page

<b>Connection head</b>	
0	None
1	BA: Aluminium, M20 x 1.5, protection category IP65
2	BUZ-S: spring lock, hinged cover, aluminium, M20 x 1.5, protection category IP65
3	BUZ-T: screw cap, hinged cover, aluminium, M20 x 1.5, protection category IP65, Ex
4	BGK: screw cap, aluminium, M20 x 1.5, protection category IP67
5	BUZ-H: raised cover, aluminium, M20 x 1.5, protection category IP65, Ex
6	BUZ-HW: raised cover with display, aluminium, M20 x 1.5, protection category IP65
7	BBK: screw cap, PA, M20 x 1.5, protection category IP54
8	BVA: screw cap, VA, M20 x 1.5, protection category IP65
L	AXD: screw cap, aluminium, M20 x 1.5, protection category IP68, Ex, pending
<b>Measuring insert (sensor / wiring)</b>	
0	None
1	1 x Pt100, 2-wire connection, Ex
2	1 x Pt100, 3-wire connection, Ex
3	1 x Pt100, 4-wire connection, Ex
4	2 x Pt100, 3-wire connection, tolerance class A, wire-wound (WW)
5	2 x Pt100, 4-wire connection, tolerance class A, wire-wound (WW), in preparation
6	2 x Pt100, 2-wire connection, tolerance class A, wire-wound (WW)
8	1 x 3-wire connection + Smart Sense
A	1 x thermocouple type J (Fe-CuNi), Ex
B	1 x thermocouple type K (NiCr-Ni), Ex
D	2 x thermocouple type J (Fe-CuNi)
E	2 x thermocouple type K (NiCr-Ni)
<b>Measuring insert / class</b>	
0	None
1	Tolerance class B, mineral insulated (Mi), thin film (TF), -70...+500°C / -94...+932°F
2	Tolerance class A, mineral insulated (Mi), thin film (TF), -50...+300°C / -58...+572°F
3	Tolerance class A, mineral insulated (Mi), thin film (TF), shock-resistant, -20...+200°C / -4...+392°F, in preparation
4	Tolerance class A, mineral insulated (Mi), wire-wound (WW), -200... +600°C / -328...+1112°F, Ex
5	Tolerance class 1/3 DIN B from 0...+150°C / -32...+302°F, above this temperature tolerance class A, mineral insulated (Mi), thin film (TF)
7	Tolerance class 1/10 DIN B at 0°C / +32°F, mineral insulated (Mi), wire-wound (WW), Ex, pending
A	Tolerance class 1, mineral insulated (Mi), thermocouple, Ex
VTS1	4
Continued on next page	

		<b>Thermowell material</b>
0	None	
1	1.4571 / 316 Ti: Ø 9/11/12 mm or Ø 0.35/0.43/0.47", up to +500°C / +932°F	
2	1.4841 / 314: Ø 10/12 mm or Ø 0.39/0.47", up to +1000°C / +1832°F (on request only)	
3	1.4404 / 316 L: Ø 10/12 mm or Ø 0.39/0.47", up to +500°C / +932°F (on request only)	
		<b>Thermowell diameter</b>
0	None	
1	9 x 1 mm / 0.35 x 0.04", straight thermowell tip, material 1.4571 / 316 Ti	
2	10 x 1 mm / 0.39 x 0.04", straight thermowell tip, materials 1.4841 / 314 and 1.4404 / 316 L	
3	11 x 2 mm / 0.43 x 0.08", material 1.4571 / 316 Ti	
4	12 x 2.5 mm / 0.47 x 0.1", material 1.4571 / 316 Ti	
5	12 x 2 mm / 0.47 x 0.08", materials 1.4841 / 314 and 1.4404 / 316 L	
		<b>Process connection</b>
0	None	
1	G½ A	
2	G¾ A	
3	G1 A	
5	½-14 NPT	
6	¾-14 NPT	
B	DN25 flange acc. to EN 1092-1	
D	DN50 flange acc. to EN 1092-1	
H	1" flange acc. to ASME B16.5	
L	1½" flange acc. to ASME B16.5	
P	Compression type fitting G½, VA	
R	Compression type fitting G¾, VA	
S	Compression type fitting ½-14 NPT, VA	
U	Clamping ring connection G½, PTFE	
V	Clamping ring connection G¾, PTFE	
X	Mounting flange UZ21	
		<b>Pressure rating</b>
0	None	
1	PN40, raised face: Form B1 acc. to EN 1092-1	
A	150 lb, raised face: RF acc. to ASME B16.5	
B	300 lb, raised face: RF acc. to ASME B16.5	
VT S1	4	Continued on next page

		<b>Insertion length</b>	
	0	None	
	1	75 mm / 3"	
	2	100 mm / 3.9"	
	3	115 mm / 4.5"	
	4	160 mm / 6.3"	
	6	225 mm / 8.9"	
	7	250 mm / 9.8"	
	8	270 mm / 10.6"	
	A	305 mm / 12"	
	B	315 mm / 12.4"	
	C	390 mm / 15.4"	
	D	395 mm / 15.6"	
	E	400 mm / 15.7"	
	F	465 mm / 18.3"	
	G	480 mm / 18.9"	
	H	545 mm / 21.5"	
	K	725 mm / 28.5"	
	Z	Special lengths (> 2000 mm / 78.4"), on request	
		<b>Neck tube length</b>	
	0	None	
	1	80 mm / 3.1"	
	3	145 mm / 5.7"	
	A	70 mm / 2.8"	
	B	90 mm / 3.5"	
	C	100 mm / 3.9"	
	D	110 mm / 4.3"	
	E	120 mm / 4.7"	
	F	130 mm / 5.1"	
	G	140 mm / 5.5"	
	H	150 mm / 5.9"	
	K	160 mm / 6.3"	
	L	170 mm / 6.7"	
	M	180 mm / 7.1"	
	N	190 mm / 7.5"	
	P	200 mm / 7.9"	
	Z	Special length, on request	
<b>VTS1</b>	<b>4</b>		Continued on next page

		<b>Connection type (with head-mounted transmitter)</b>	
		0	Measuring insert with flying wires for transmitter assembly
		1	Measuring insert with ceramic terminal block
		2	TT 10 C, analogue, Ex
		3	TT 11 C, analogue, 0...10 VDC, only Pt100
		5	TT 20 C, analogue, programmable
		7	TT 30 C, digital, standard, Ex
		A	TT 40 C, digital, precise
		D	TT 50 C, digital, HART <sup>®</sup> , Ex
		E	TT 51 C, digital, HART <sup>®</sup> , also SIL2, Ex
		F	TT 60 C, digital, Profibus-PA, Ex
		<b>Connection type (only rail-mount transmitter)</b>	
		0	None
		1	TT 10 R, analogue
		2	TT 11 R, analogue, 0...10 VDC, only Pt100
		4	TT 20 R, analogue, programmable, in preparation
		6	TT 30 R, digital, standard, Ex
		7	TT 31 R, 1 channel, Ex
		8	TT 31 R, 2 channel, Ex
		A	TT 32 R, 90...250 VAC
		B	TT 32 R, 20...30 VDC
		D	TT 40 R, digital, precise
		G	TT 50 R, digital, HART <sup>®</sup>
		H	TT 51 R, digital, HART <sup>®</sup> , also SIL2, Ex
		K	TT 60 R, digital, Profibus-PA
VTS1	4	Continued on next page	

		<b>Measuring range</b>	
		0	Without transmitter
		1	Customised
		2	-50...+50°C / -58...+122°F
		3	-50...+100°C / -58...+212°F
		4	-50...+150°C / -58...+302°F
		5	0...+50°C / +32...+122°F
		6	0...+100°C / +32...+212°F
		7	0...+150°C / +32...+302°F
		8	0...+200°C / +32...+392°F
		A	0...+250°C / +32...+482°F
		B	0...+300°C / +32...+572°F
		C	0...+350°C / +32...+662°F
		D	0...+400°C / +32...+752°F
		E	0...+450°C / +32...+842°F
		F	0...+500°C / +32...+932°F
		G	0...+600°C / +32...+1112°F
		H	0...+800°C / +32...+1472°F
		K	0...+1000°C / +32...+1832°F
		<b>Certificates</b>	
		0	None
		1	1 point, room temperature (single or double sensor)
		2	2 points: 0°C / 32°F and 100°C / 212°F (single sensor)
		3	2 points: 0°C / 32°F and 100°C / 212°F (double sensor)
		4	3 points: 0°C / 32°F, 100°C / 212°F and 200°C / 392°F (single sensor)
		5	3 points: 0°C / 32°F, 100°C / 212°F and 200°C / 392°F (double sensor)
		6	Calibration according to customer specifications (single sensor)
		7	Calibration according to customer specifications (double sensor)
VTS1	4	Continued on next page	

		<b>"Certificates"</b> continued	
A		2 points: 0 and 100% (single sensor & transmitter)	
B		3 points: 0, 50 and 100% (single sensor & transmitter)	
C		5 points: 0, 25, 50, 75 and 100% (single sensor & transmitter)	
E		2 points: 0 and 100% (single sensor & transmitter), including adjustment	
F		3 points: 0, 50 and 100% (single sensor & transmitter), including adjustment	
G		5 points: 0, 25, 50, 75 and 100% (single sensor & transmitter), including adjustment	
H		Calibration according to customer specifications (single sensor & transmitter), including adjustment	
		<b>Certificate of compliance with the order</b>	
0		None	
1		2.1 acc. to EN 10204	
		<b>Pressure test</b>	
0		None	
1		With APZ 3.1 acc. to EN 10204	
		<b>Material test/certification</b>	
0		None	
1		Material quality certificate 3.1 according to EN 10204	
2		PMI metallic, pressurized and wetted parts, APZ 3.1	
4		Material quality certificate 3.1 and PMI APZ 3.1	
		<b>Marking</b>	
0		None	
1		Stainless steel plate, 40 x 20 mm / 1.57 x 0.79"	
2		Stainless steel plate, 120 x 46 mm / 4.72 x 1.81"	
3		Stainless steel plate, 15 x 50 mm / 0.59 x 1.97"	
6		PVF plate, 45 x 15 mm / 1.77 x 0.59"	
A		Label, 95 x 45 mm / 3.74 x 1.77"	
B		Stainless steel plate and label, 40 x 20 mm / 1.57 x 0.79"	
C		Stainless steel plate and label, 120 x 46 mm / 4.72 x 1.81"	
VTS1	4	Continued on next page	

	<b>Operating instructions</b>	
	0	None
	1	German
	3	English
	4	French
	5	Spanish
	7	Italian
	8	Swedish (in preparation)
	G	German / English
	<b>Private Label</b>	
	1	INOR
	B	Manufacturer neutral, pending
	<b>Version</b>	
	0	None
1	SIL2	
VTS1	4	Complete type code

## 5.2 Type code VTS4

- The following type code is valid for TRA and TCA-P40/S41/F42.
- The characters of the type code highlighted in light grey describe the standard.
- "Ex" indicates that the version in question is available in both the non-Ex and Ex version.

<b>VTS4</b>	<b>4</b>	<b>Type</b>
	1	TRA-P40: insertion-type resistance thermometer, Ex
	2	TRA-S41: threaded resistance thermometer with neck tube, Ex
	3	TRA-F42: flange resistance thermometer with neck tube, Ex
	A	TCA-P40: insertion-type thermocouple, Ex
	B	TCA-P41: threaded thermocouple with neck tube, Ex
	C	TCA-P42: flange thermocouple with neck tube, Ex
		<b>Approval</b>
	0	None
	1	ATEX - II 1G Ex ia IIC T6 (Gas) and II 1D Ex iaD 20 IP65 T140°C/284°F (Dust)
	2	ATEX - II 1/2G Ex ia IIC T6 (Gas) and II 1D Ex iaD 20 IP65 T140°C/284°F (Dust)
		<b>Connection head</b>
	0	None
	1	BA: Aluminium, M20 x 1.5, protection category IP65
	2	BUZ-S: spring lock, hinged cover, aluminium, M20 x 1.5, protection category IP65
	3	BUZ-T: screw cap, hinged cover, aluminium, M20 x 1.5, protection category IP65, Ex
	4	BGK: screw cap, aluminium, M20 x 1.5, protection category IP67
	5	BUZ-H: raised cover, aluminium, M20 x 1.5, protection category IP65, Ex
	6	BUZ-HW: raised cover with display, aluminium, M20 x 1.5, protection category IP65
	7	BBK: screw cap, PA, M20 x 1.5, protection category IP54
	8	BVA: screw cap, VA, M20 x 1.5, protection category IP65
	L	AXD: screw cap, aluminium, M20 x 1.5, protection category IP68, Ex, pending
<b>VTS4</b>	<b>4</b>	Continued on next page

		<b>Measuring insert (sensor / wiring)</b>	
0	None		
1	1 x Pt100, 2-wire connection, Ex		
2	1 x Pt100, 3-wire connection, Ex		
3	1 x Pt100, 4-wire connection, Ex		
4	2 x Pt100, 3-wire connection, tolerance class A, wire-wound (WW)		
5	2 x Pt100, 4-wire connection, tolerance class A, wire-wound (WW), in preparation		
6	2 x Pt100, 2-wire connection, tolerance class A, wire-wound (WW)		
8	1 x 3-wire connection + Smart Sense		
A	1 x thermocouple type J (Fe-CuNi), Ex		
B	1 x thermocouple type K (NiCr-Ni), Ex		
D	2 x thermocouple type J (Fe-CuNi)		
E	2 x thermocouple type K (NiCr-Ni)		
		<b>Measuring insert / class</b>	
0	None		
1	Tolerance class B, mineral insulated (Mi), thin film (TF), -70...+500°C / -94...+932°F		
2	Tolerance class A, mineral insulated (Mi), thin film (TF), -50...+300°C / -58...+572°F		
3	Tolerance class A, mineral insulated (Mi), thin film (TF), shock-resistant, -20...+200°C / -4...+392°F, in preparation		
4	Tolerance class A, mineral insulated (Mi), wire-wound (WW), -200... +600°C / -328...+1112°F, Ex		
5	Tolerance class 1/3 DIN B from 0...+150°C / -32...+302°F, above this temperature tolerance class A, mineral insulated (Mi), thin film (TF)		
7	Tolerance class 1/10 DIN B at 0°C / +32°F, mineral insulated (Mi), wire-wound (WW), Ex, pending		
A	Tolerance class 1, mineral insulated (Mi), thermocouple, Ex		
		<b>Thermowell material</b>	
0	None		
1	1.4571 / 316Ti: up to +500°C / +932°F		
2	1.4841 / 314: up to +1000°C / +1832°F, on request		
		<b>Thermowell diameter</b>	
0	None		
4	12 x 2.5 mm / 0.47 x 0.1"		
VTS4	4	Continued on next page	

		<b>Process connection</b>	
0	None		
1	G½ A		
2	G¾ A		
3	G1 A		
5	½-14 NPT		
6	¾-14 NPT		
B	DN25 flange acc. to EN 1092-1		
D	DN50 flange acc. to EN 1092-1		
H	1" flange acc. to ASME B16.5		
L	1½" flange acc. to ASME B16.5		
P	Compression type fitting G½, VA		
R	Compression type fitting G¾, VA		
S	Compression type fitting ½ NPT, VA		
U	Clamping ring connection G½, PTFE		
V	Clamping ring connection G¾, PTFE		
X	Mounting flange UZ21		
		<b>Pressure rating</b>	
0	None		
1	PN40, raised face: Form B1 acc. to EN 1092-1		
A	150 lb, raised face: RF acc. to ASME B16.5		
B	300 lb, raised face: RF acc. to ASME B16.5		
		<b>Insertion length</b>	
0	None		
1	160 mm / 6.3"		
2	220 mm / 8.7"		
3	225 mm / 8.9"		
4	280 mm / 11.0"		
5	285 mm / 11.2"		
6	307 mm / 12.1"		
7	345 mm / 13.6"		
8	367 mm / 14.4"		
A	427 mm / 16.8"		
Z	Special lengths (> 2000 mm / 78.4"), on request		
VTS4	4	Continued on next page	

		<b>Neck tube length</b>	
		0	None
		1	80 mm / 3.1"
		2	82 mm / 3.2"
		3	145 mm / 5.7"
		4	147 mm / 5.8"
		A	70 mm / 2.8"
		B	90 mm / 3.5"
		C	100 mm / 3.9"
		D	110 mm / 4.3"
		E	120 mm / 4.7"
		F	130 mm / 5.1"
		G	140 mm / 5.5"
		H	150 mm / 5.9"
		K	160 mm / 6.3"
		L	170 mm / 6.7"
		M	180 mm / 7.1"
		N	190 mm / 7.5"
		P	200 mm / 7.9"
		Z	Special length
		<b>Connection type (with head-mounted transmitter)</b>	
		0	Measuring insert with flying wires for transmitter assembly
		1	Measuring insert with ceramic terminal block
		2	TT 10 C, analogue, Ex
		3	TT 11 C, analogue, 0...10 VDC, only Pt100
		5	TT 20 C, analogue, programmable
		7	TT 30 C, digital, standard, Ex
		A	TT 40 C, digital, precise
		D	TT 50 C, digital, HART <sup>®</sup> , Ex
		E	TT 51 C, digital, HART <sup>®</sup> , also SIL2, Ex
		F	TT 60 C, digital, Profibus-PA, Ex
VTS4	4	Continued on next page	

<b>Connection type (only rail-mount transmitter)</b>		
0	Without transmitter	
1	TT 10 R, analogue	
2	TT 11 R, analogue, 0...10 VDC, only Pt100	
4	TT 20 R, analogue, programmable, in preparation	
6	TT 30 R, digital, standard, Ex	
7	TT 31 R, 1 channel, Ex	
8	TT 31 R, 2 channel, Ex	
A	TT 32 R, 90...250 VAC	
B	TT 32 R, 20...30 VDC	
D	TT 40 R, digital, precise	
G	TT 50 R, digital, HART®	
H	TT 51 R, digital, HART®, also SIL2, Ex	
K	TT 60 R, digital, Profibus-PA	
<b>Transmitter configuration</b>		
0	Without transmitter	
1	Customised	
2	-50...+50°C / -58...+122°F	
3	-50...+100°C / -58...+212°F	
4	-50...+150°C / -58...+302°F	
5	0...+50°C / +32...+122°F	
6	0...+100°C / +32...+212°F	
7	0...+150°C / +32...+302°F	
8	0...+200°C / +32...+392°F	
A	0...+250°C / +32...+482°F	
B	0...+300°C / +32...+572°F	
C	0...+350°C / +32...+662°F	
D	0...+400°C / +32...+752°F	
E	0...+450°C / +32...+842°F	
F	0...+500°C / +32...+932°F	
G	0...+600°C / +32...+1112°F	
H	0...+800°C / +32...+1472°F	
K	0...+1000°C / +32...+1832°F	
VTS4	4	Continued on next page

		<b>Certificates</b>	
		0	None
		1	1 point, room temperature (single or double sensor)
		2	2 points: 0°C / 32°F and 100°C / 212°F (single sensor)
		3	2 points: 0°C / 32°F and 100°C / 212°F (double sensor)
		4	3 points: 0°C / 32°F, 100°C / 212°F and 200°C / 392°F (single sensor)
		5	3 points: 0°C / 32°F, 100°C / 212°F and 200°C / 392°F (double sensor)
		6	Calibration according to customer specifications (single sensor)
		7	Calibration according to customer specifications (double sensor)
		A	2 points: 0 and 100% (single sensor & transmitter)
		B	3 points: 0, 50 and 100% (single sensor & transmitter)
		C	5 points: 0, 25, 50, 75 and 100% (single sensor & transmitter)
		E	2 points: 0 and 100% (single sensor & transmitter), including adjustment
		F	3 points: 0, 50 and 100% (single sensor & transmitter), including adjustment
		G	5 points: 0, 25, 50, 75 and 100% (single sensor & transmitter), including adjustment
		H	Calibration according to customer specifications (single sensor & transmitter), including adjustment
		<b>Certificate of compliance with the order</b>	
		0	None
		1	2.1 acc. to EN 10204
		<b>Pressure test</b>	
		0	None
		1	With APZ 3.1 acc. to EN 10204
		<b>Material test/certification</b>	
		0	None
		1	Material quality certificate 3.1 acc. to EN 10204
		2	PMI metallic, pressurized and wetted parts, APZ 3.1
		4	Material quality certificate 3.1 and PMI APZ 3.1
VTS4	4	Continued on next page	

	<b>Marking</b>	
	0	None
	1	Stainless steel plate, 40 x 20 mm / 1.57 x 0.79"
	2	Stainless steel plate, 120 x 46 mm / 4.72 x 1.81"
	3	Stainless steel plate, 15 x 50 mm / 0.59 x 1.97"
	6	PVF plate, 45 x 15 mm / 1.77 x 0.59"
	A	Label, 95 x 45 mm / 3.74 x 1.77"
	B	Stainless steel plate and label, 40 x 20 mm / 1.57 x 0.79"
	C	Stainless steel plate and label, 120 x 46 mm / 4.72 x 1.81"
	<b>Operating instructions</b>	
	0	None
	1	German
	3	English
	4	French
	5	Spanish
	7	Italian
	8	Swedish (in preparation)
	G	German / English
	<b>Private Label</b>	
	1	INOR
	B	Manufacturer neutral, pending
<b>Version</b>		
0	None	
1	SIL2	
<b>VTS4</b>	<b>4</b>	Complete type code

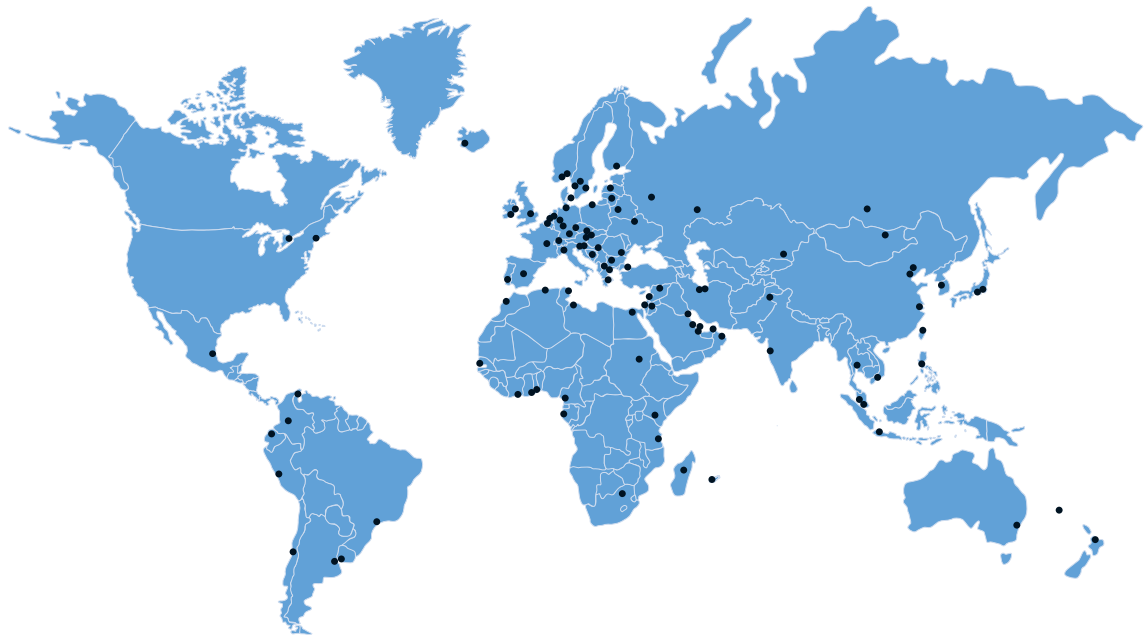

## INOR product overview

- Temperature Sensors
- Temperature Transmitters
- INOR Connect
- Thermowells
- Isolators & Isolation Transmitters
- Pyrometers
- Multipoint Sensors
- Field Housing & Indicators
- Alarm Units
- Accessories

Head Office

### **INOR Process AB**

P.O. Box 9125  
200 39 Malmö  
Sweden

Phone: +46(0)40-312 560  
sales@inor.se  
www.inor.se

**INOR**